

PLATINUM

May 2021

Mastermind Event

Brisbane

**Tamara Read &
Nicolle Beer**
QLD State Coaches



I LOVE
REAL ESTATE

Event Outline -

- 6:00 – 6:30 Networking
- 6:30 - Start
- 6:30 – 6:45 Housekeeping
- 6:45 – 8:00 Accountability
- 8:00 – 8:30 Networking Break
- 8:30 – 10:30 Construction

Workshop Format

- Use microphone
- Involve everyone in the conversation
- Be supportive
- Order food and drinks downstairs



Housekeeping



Housekeeping

- 2021 Monthly Dates (Tuesday's):
 - ❖ 1st June; 6th July; 3rd Aug; 7th Sept; 5th Oct; 2nd Nov, 7th Dec
- 2021 National Conference Dates:
 - ❖ 7th & 8th August – Sunshine Coast
 - ❖ 4th & 5th December – Sunshine Coast
 - ❖ KEEP Saturday night free
 - ❖ Graduate Only Day prior to each National Conference Date



Housekeeping

- 2021 Ultimate Bootcamp Dates:

- ❖ Melbourne: 25 - 27th June
- ❖ Sydney: 29 - 31st October

- 2021 Other Ultimate Dates:

- ❖ Realestate Millionaire Within – Sunshine Coast: 5-6th June
- ❖ I Love Realestate Super Conference – Sunshine Coast:
19 - 21st Nov



Housekeeping

- **2021 Quantum Events:** Check Ultimate Website For Full List
 - ❖ 25% Developers Club – Virtual: 24 - 25th July
 - ❖ Commercial Secrets - Virtual: 18 – 19th September
 - ❖ Fast Profits – Virtual: 16-17th October
 - ❖ Extreme Income – Virtual 23 – 24th October

Housekeeping

- Audio Only Files of Monthly Webinars:
- ❖ PA Website / Education / Monthly Webinars / March - Joint Ventures / Read More

March – Joint Ventures Webinar – (2hrs 29mins)

Monthly Webinars

Edit

Reasons Why People Do a JV?

- Some people have equity & serviceability but **no time**
- Some people equity & serviceability but **no knowledge**
- Some people have equity but **no serviceability**
- Some have serviceability but **no equity**
- Some people have **no serviceability or equity** but have knowledge & time
- Some people can do more by **pooling their resources** – more deals or larger deals

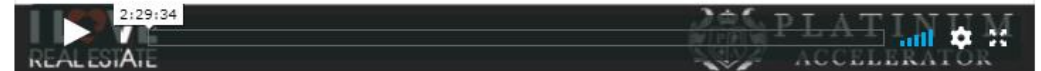

[Download Webinar \(MP4\)](#)

[Download Audio \(MP3\)](#)

[Download Slides \(PDF\)](#)

Housekeeping

○ Video of Past Monthly Meetings:

- ❖ Each monthly meeting is filmed in one State each month and uploaded onto PA website with video, slides, & workbook.
- ❖ PA Website / Meeting Recordings / Monthly Meetings

September 2018 – Dual Lot – QLD

Meeting Recordings

Edit

Meeting Recording



Download MP4

Download Slides (PDF)

Download Workbook (PDF)

← Previous

Platinum Student Meetups

- ❖ PA Website / Platinum Schedule
- ❖ Must have your Facebook account / profile open to access the links



PA Student Meetup Groups

These Student Meetup groups are for ALL Platinum students only, both past and present. They are organised by Platinum students to facilitate networking between Platinums and staying connected with the awesome Platinum family. Typically they occur between the PA Monthly Meetings.

NOTE: You MUST have your Facebook Account/Profile open to access these links.

Brisbane Student Meetup



Student Organizer – Megan Humphreys

Click on the link below to access the Platinum Accelerator Facebook Events for each Brisbane Student Meetup. All of the upcoming dates, location, times and RSVP information is in these events.

[Brisbane Student Meetup](#)

Sydney Student Meetup



Student Organizer – Cindy Luok

Click on the link below to access the Platinum Accelerator Facebook Events for each Sydney Student Meetup. All of the upcoming dates, location, times and RSVP information is in these events.

[Sydney Student Meetup](#)

Melbourne Student Meetup



Student Organizer – Aygun Ozkan

Click on the link below to access the Platinum Accelerator Facebook Events for each Melbourne Student Meetup. All of the upcoming dates, location, times and RSVP information is in these events.

[Melbourne Student Meetup](#)

Perth Student Meetup



Student Organizer – Basia Garbowska & Heath Worlton

Click on the link below to access the Platinum Accelerator Facebook Events for each Melbourne Student Meetup. All of the upcoming dates, location, times and RSVP information is in these events.

[Perth Student Meetup](#)

Events Tab – Platinum Facebook

Platinum Facebook:

- ❖ Events
- ❖ Monthly Meetings
- ❖ Student Meetups
- ❖ National Conferences



Platinum Accelerator
Closed group

About
Discussion
Chats
Announcements
Members
Events
Videos
Photos
Files
Group Insights
Recommendations
Moderate Group

Search this group

Shortcuts
Platinum Accelerator
Ultimate Real Estat... 20+
Brisbane - I Love Re... 2

Events Calendar Settings + Create Event

Recurring

- QLD Monthly Meetings - Platinum Accelerator**
Novotel Brisbane in Brisbane, Queensland, Australia
Michael Dempsey invited you.
Next event occurs on Apr 2 at 6:30 PM. See All
Going Maybe Can't Go Edit Cancel
- WA Monthly Meetings - Platinum Accelerator**
Novotel Perth Langley in Perth, Western Australia
Michael Dempsey invited you.
Next event occurs on Apr 3 at 8:30 PM. See All
Going Maybe Can't Go Edit Cancel
- VIC Monthly Meetings - Platinum Accelerator**
Rydges Hotels & Resorts in Melbourne, Victoria, Australia
Michael Dempsey invited you.
Next event occurs on Apr 4 at 5:30 PM. See All
Going Maybe Can't Go Edit Cancel
- NSW Monthly Meetings - Platinum Accelerator**
Novotel Sydney Central in Sydney, Australia
Michael Dempsey invited you.
Next event occurs on Apr 4 at 5:30 PM. See All
Going Maybe Can't Go Edit Cancel
- Brisbane Student Meetups**
Prince of Wales Hotel in Brisbane, Queensland, Australia
Megan Humphreys invited you.
Next event occurs on Apr 13 at 5:00 PM. See All
Going Maybe Can't Go Edit Cancel
- Melbourne Student Meetup**
199 William St, Melbourne VIC 3000, Australia
Aygün Ozkan invited you.
Next event occurs on Apr 18 at 7:00 PM. See All
Going Maybe Can't Go Edit Cancel

4123697/?acontext=%7B"ref"%3A"4"%2C"acti...

PLATINUM



I LOVE
REAL ESTATE

Perception

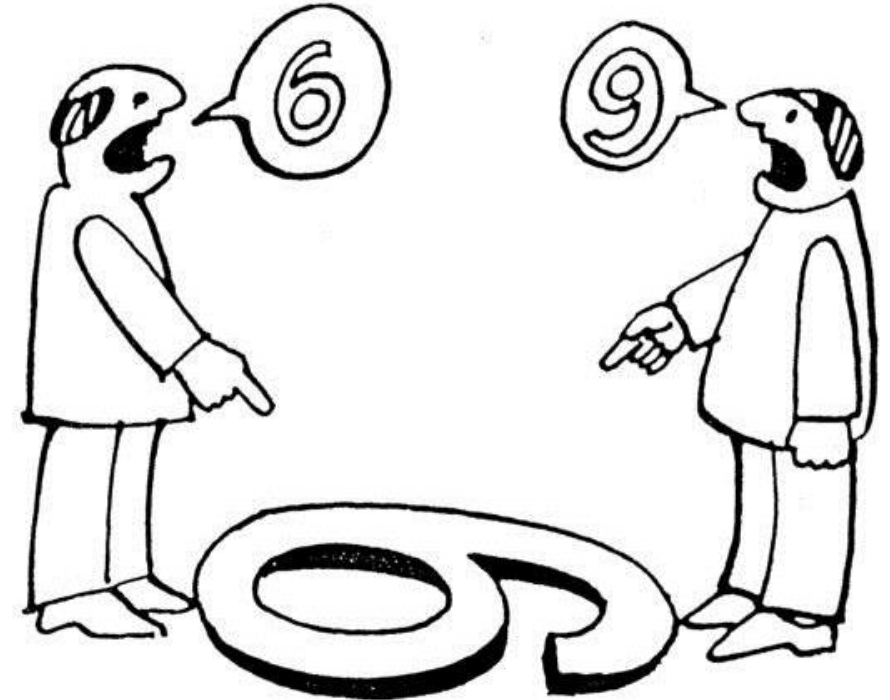



Perception:

- Can be deceptive
- Determines how we re-act to situations and people
- Determines how people re-act to us
- Can either make relationships or destroy them
- Can either make opportunities or destroy them

Your perception of others and situations determines how you respond to people and situations and therefore what results you get.

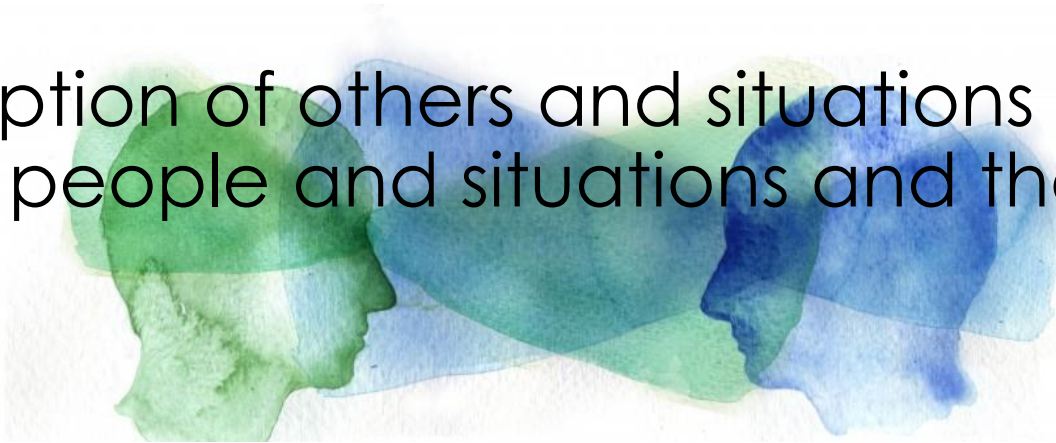

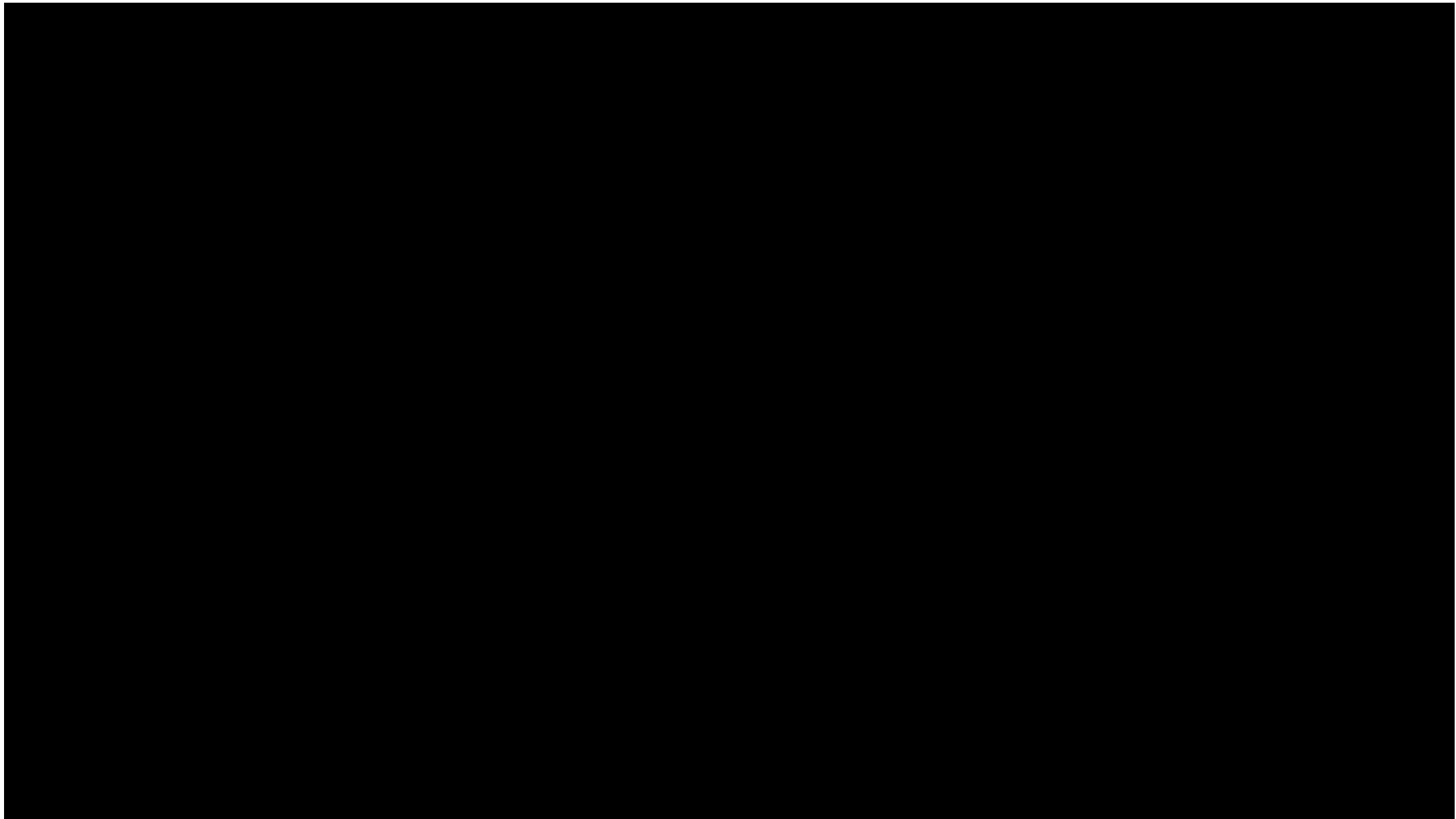

What do you need to change to get the results you want?

- Is there a situation where you feel you are banging your head against a brick wall?
- What is your attitude around that particular situation?
- What needs to change in you to shift the energy around that situation?
- What steps can you take to get the result you want?
- **REMEMBER – every external experience you are having, you have created in form by your perception and resultant reaction.**

PLATINUM

Accountability
Monthly Goals



I LOVE
REAL ESTATE

Buddy Process Follow-Up



- Partner with someone you don't know
- Active Platinum Partners split up (Non-active partners stay together)
- Exchange Mobile No.
- Schedule to "TALK" weekly
- Finishing students partner together

Last Month In Review

Share Your Successes and Challenges

SUCCESS

SUCCESS

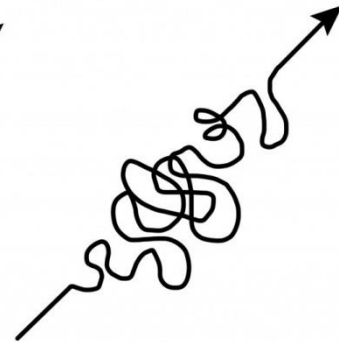
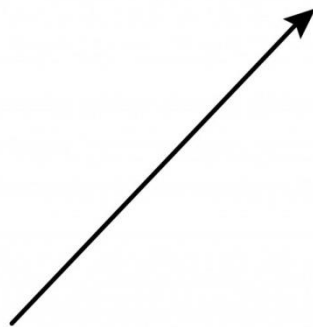

what people think
it looks like

what it really
looks like

This Months Plan

Share Your
Key Goals For Month

Monthly
✓
goals



Tea / Coffee Break

PLATINUM

CONSTRUCTION

TRIVIA!



I LOVE
REAL ESTATE

Activity

- Groups of 2-3 people
- Builders & Graduates please answer last in your group – give others a go first 😊
- Record your answers on the recording sheet



TRIVIA – RECORDING SHEET



QU	ANSWER	POINTS
1		
2		
3		
4		
5		
6		
7		
8		
9		
10		
11		
12		
13		
14		
15		
16		
17		
18		
19		
20		
21		
22		
23		

Construction Process

- Phase 1 – Design, Planning, Team
- Phase 2 – Costings & Contract
- Phase 3 – Execution – Finance, Insurance, Build

QUESTIONS THEN ANSWERS

PHASE 1

Design, Planning, Team

Question 1

Which professional is the **best** to speak to regarding underground sewer, water and stormwater design and cost estimates:

- a) Town planner
- b) Structural Engineer
- c) Civil Engineer
- b) Land Surveyor



Question 2 (See Workbook)

THINGS IN COMMON

	Dual Occupancy (Auxiliary unit)	Dwelling House (Secondary dwelling)	Additional Notes
ONE LOT	✓	✓	Neither a Dual Occupancy (Auxiliary unit) nor a Dwelling House (Secondary dwelling) can be subdivided into two lots.
COMPARATIVE SIZE	✓	✓	Unlike a traditional Dual Occupancy (duplex) one dwelling must be 'big' (the primary dwelling) and one must be 'small' (the Auxiliary unit / Secondary dwelling).
GROSS FLOOR AREA (GFA)	✓	✓	The maximum size of the Auxiliary unit / Secondary dwelling is restricted to: <ul style="list-style-type: none"> • 70m² if in the residential zone category and on a lot less than 1000m² in size or • 100m² if in the residential zone category and on lots over 1000m² in size GFA excludes garages, carports, decks and patios.
LOCATION	✓	✓	In addition to the standard building setbacks of the planning scheme, both forms of development can be located beside, incorporated within (above or under) or behind but not in front of the primary dwelling.
SELF CONTAINED	✓	✓	Both can be self-contained and have separate entrances.
RUBBISH BIN	✓	✓	Additional bins are permitted subject to charge.
ATTACHED	✓	✓	Both dwelling can be attached or separated by no more than 20m.



Question 2

Based on the information provided, assuming that you have found a property that's 600m² in total land size, in the residential zone, that has enough room to the side of the existing dwelling to construct this design, with adequate parking and only one crossover (entry). Would this floor plan fit the planning / design criteria to be approved as an auxiliary dwelling (granny flat)?

- a) True
- b) False

Question 3

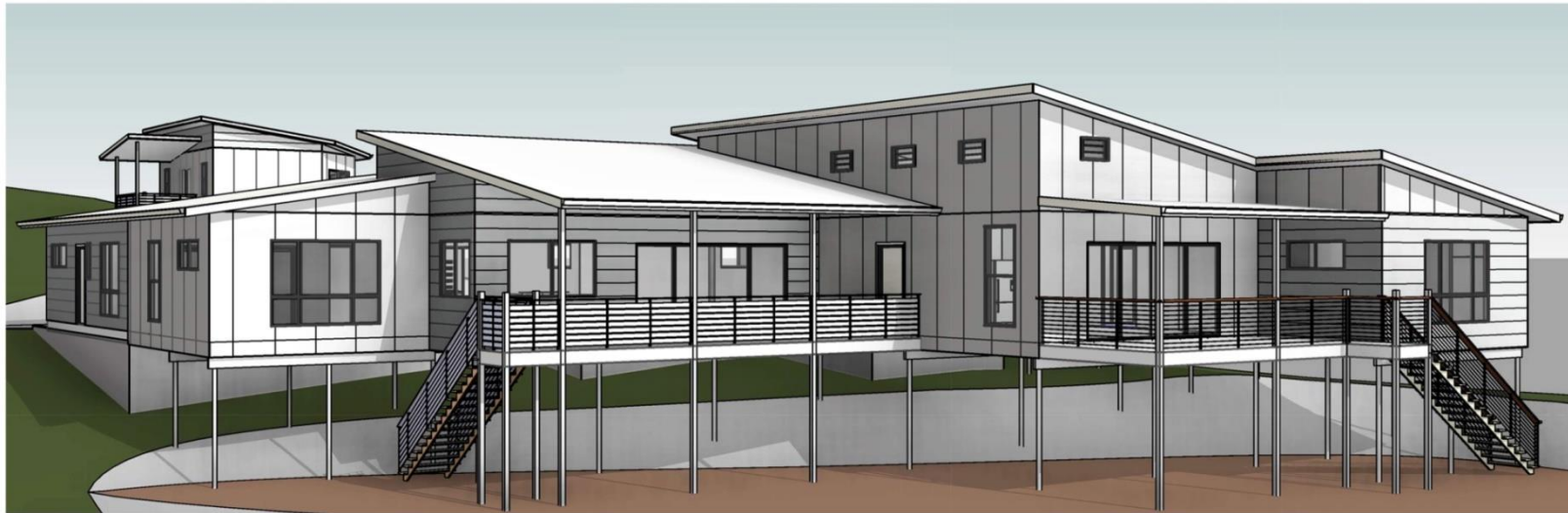

List at least 4 cost saving ideas:

1) _____

2) _____

3) _____

4) _____

Question 4

On the 1,012m² property below (highlighted yellow boundaries), calculate the maximum area for a building to cover, inclusive of garages and patios.



Planning Information:

- Height allowance 9mtrs
- 1 dwelling / 250m²
- 5 metre front set back
- 6 metre rear set back
- 2 metre side set backs
- Site coverage 60%

Question 5

When sourcing multiple build quotes – list 3 ways to reduce the variability between quotes.

1) _____

2) _____

3) _____



Question 6

List 5 ways to source a builder in your area?

1) _____

2) _____

3) _____

4) _____

5) _____



Question 7

List 5 examples of how you can complete a due diligence check on a builder?

1) _____

2) _____

3) _____

4) _____

5) _____



ANSWERS

Design, Planning, Team

Question 1

1 Point

Which professional is the **best** to speak to regarding underground sewer, water and stormwater design and cost estimates:

- a) Town planner
- b) Structural Engineer
- c) Civil Engineer
- b) Land Surveyor



Question 2 (References)

THINGS IN COMMON

	Dual Occupancy (Auxiliary unit)	Dwelling House (Secondary dwelling)	Additional Notes
ONE LOT	✓	✓	Neither a Dual Occupancy (Auxiliary unit) nor a Dwelling House (Secondary dwelling) can be subdivided into two lots.
COMPARATIVE SIZE	✓	✓	Unlike a traditional Dual Occupancy (duplex) one dwelling must be 'big' (the primary dwelling) and one must be 'small' (the Auxiliary unit / Secondary dwelling).
GROSS FLOOR AREA (GFA)	✓	✓	The maximum size of the Auxiliary unit / Secondary dwelling is restricted to: <ul style="list-style-type: none"> • 70m² if in the residential zone category and on a lot less than 1000m² in size or • 100m² if in the residential zone category and on lots over 1000m² in size GFA excludes garages, carports, decks and patios.
LOCATION	✓	✓	In addition to the standard building setbacks of the planning scheme, both forms of development can be located beside, incorporated within (above or under) or behind but not in front of the primary dwelling.
SELF CONTAINED	✓	✓	Both can be self-contained and have separate entrances.
RUBBISH BIN	✓	✓	Additional bins are permitted subject to charge.
ATTACHED	✓	✓	Both dwelling can be attached or separated by no more than 20m.



Question 2

1 Point

Based on the information provided, assuming that you have found a property that's 600m² in total land size, in the residential zone, that has enough room to the side of the existing dwelling to construct this design, with adequate parking and only one crossover (entry). Would this floor plan fit the planning / design criteria to be approved as an auxiliary dwelling (granny flat)?

a) True

b) False

Question 3

4 Points



List at least 4 cost saving ideas:

Reduce:

1) Floor area

2) Wall articulation

3) Roof complexity

4) Ceiling height

- High windows

- Driveway concrete

Question 4

1 Point

On the 1012m² property below (highlighted yellow boundaries), calculate the maximum area for a building to cover, inclusive of garages and patios.



Planning Information:

- Height allowance 9mtrs
- 1 dwelling / 250m²
- 5 metre front set back
- 6 metre rear set back
- 2 metre side set backs
- Site coverage 60%

$$1012\text{m}^2 \times 0.6 = 607\text{m}^2$$

Question 5

3 Points

When sourcing multiple build quotes – list 3 ways to reduce the variability between quotes.

1) Provide specifications document

2) Make selection of finishes up front – make/model/photos

3) Provide prime cost allowances for items not yet selected e.g. tiles

- Provide electrical plans, tiling plan etc.

- Do detailed soil testing where rock may exist – assist groundworks



Question 6

5 Points

List 5 ways to source a builder in your area?

- 1) Referrals
- 2) Builders signs around neighborhood
- 3) Building broker
- 4) Building association
- 5) Visit display village

- Internet search (i.e. Google); Realestate agent selling new product



Question 7

5 Points

List 5 examples of how you can complete a due diligence check on a builder?

1) View finished projects – recent & older

2) Call insurers

3) Speak to real estate agents that sold previous

4) Make contact with existing clients

5) Visit tradies & ask questions



- Contact suppliers
- Call Building License Authority – do building license search
- Do ASIC Company search



Leader Board

PHASE 2

Costings & Contract

Question 8

When it comes to calculating build costs, which group below is the most appropriate:

- a) Town planner, land surveyor, council, designer / architect
- b) Designer / architect, land surveyor, builders
- c) Town planner, structural engineer, civil engineer, traffic engineer
- d) Builders, designer / architect, quantity surveyors
- e) Dymphna and your coach

Question 9

When you ask a builder for a \$ / sq mtr rate, this normally means that it's a full turn key, medium level spec, fully approved (incl. approvals, certification etc.), inclusive of all garages, patio and inclusive of GST?

a) True

b) False

Question 10

All 3 designs are 250m² in area. List 3 reasons why it is inaccurate to refer to square meterage rates from a builder?

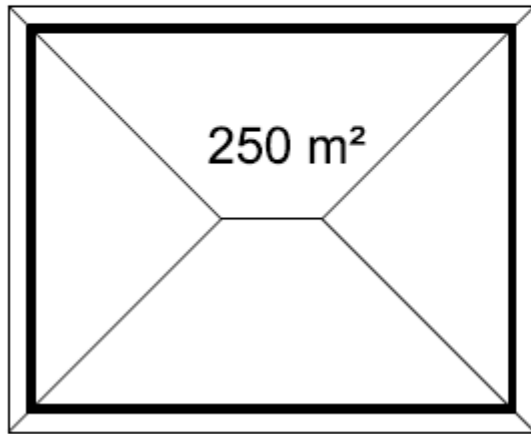

DESIGN A

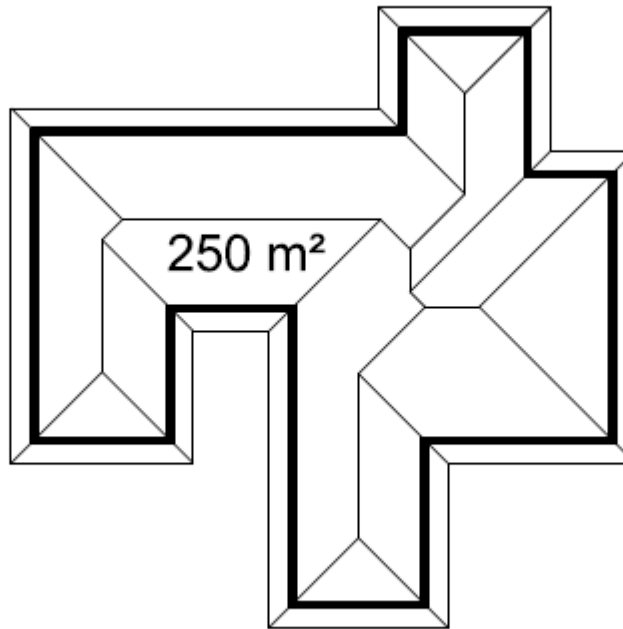

DESIGN B

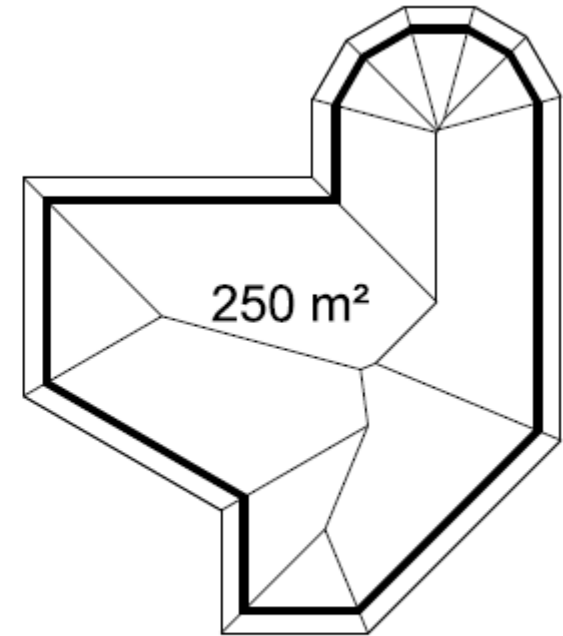

DESIGN C

Question 11

Which 3 items might be listed as prime cost items in a builders quote?

- a) Rock Excavation
- b) Oven
- c) Tiles
- d) Landscaping
- e) Front door
- f) Fencing



Question 12

Put in order the 6 main building stages as per a standard builders contract:

Lock-up
Frame
Deposit
Practical Completion
Fixing
Base



Question 13

You have received a copy of a build contract to sign & notice that the builder has nominated \$25 / day for any liquidated damages (late completion). If your peak debt in the project is \$1,000,000 & assuming a 5% interest rate, what would be a reasonable liquidated damages amount to counter with?

- a) \$257 / day
- b) \$53 / day
- c) \$137 / day
- d) \$312 / day
- e) None of the above - \$25 / day is fair and reasonable



Question 14 (See Workbook)

You are in a meeting with the builder completing the build contract for a house build of \$230,000.

Complete the progress payment schedule section of the contract.

Schedule 2. Progress payments

Part A - Prescribed progress payment schedule

This part applies unless Part B is completed.

Section 66 of the Domestic Building Contracts Act prescribes the following payment schedule:

Stage	Percent	Amount
Deposit	5.00%	
Base	10.00%	
Frame	15.00%	
Enclosed	35.00%	
Fxing	20.00%	
Practical Completion	15.00%	
Total	100.00%	

Question 15

In the same meeting with the builder, you are reviewing the HIA build contract. What 3 pieces of information are missing from the description of each plan set?

Special Conditions

Other documents forming part of the contract:

- Working Drawings
- Structural Engineering Plans
- Civil Plans
- Soil / Site Classification Report
- Hydraulic Plans
- Landscape Plan
- Plumbing Approval
- Building Approval

Owner Copy



© Copyright

Page 10 of 36

Initials:

ANSWERS

Costings & Contract

Question 8

1 Point

When it comes to calculating build costs, which group below is the most appropriate:

- a) Town planner, land surveyor, council, designer / architect
- b) Designer / architect, land surveyor, builders
- c) Town planner, structural engineer, civil engineer, traffic engineer
- d) Builders, designer / architect, quantity surveyors
- e) Dymphna and your coach

Question 9

1 Point

When you ask a builder for a \$ / sq mtr rate, this normally means that it's a full turn key, medium level spec, fully approved (incl. approvals, certification etc.), inclusive of all garages, patio and inclusive of GST?

a) True

b) False



Question 10

3 Points

All 3 designs are 250m² in area. List 3 reasons why it is inaccurate to refer to square meterage rates from a builder?

- External wall length differs
- Roof complexity differs
- Custom design effects price – complex angles, custom windows / joinery

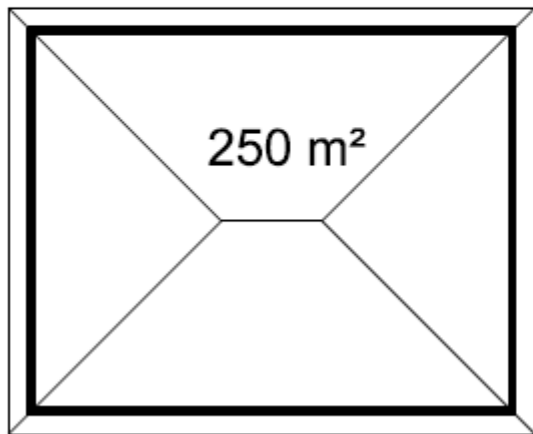

DESIGN A

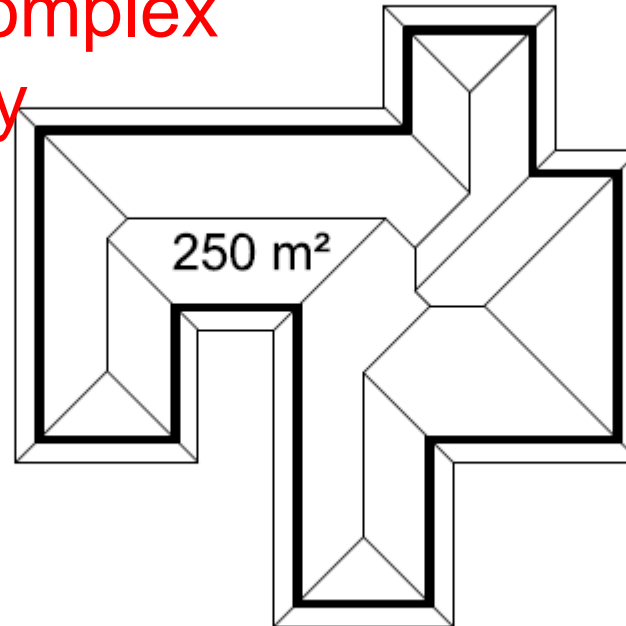

DESIGN B

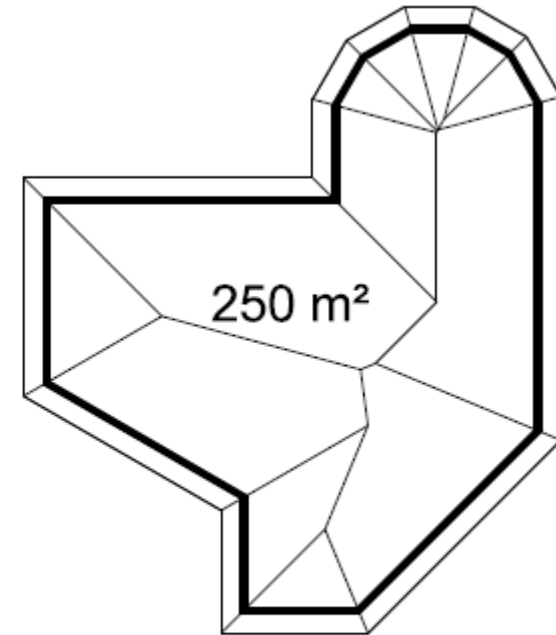

DESIGN C

Question 11

3 Points

Which 3 items might be listed as prime cost items in a builders quote?

- a) Rock Excavation
- b) Oven
- c) Tiles
- d) Landscaping
- e) Front door
- f) Fencing



Question 12

Put in order the 6 main building stages as per a standard builders contract:

Lock-up
Frame
Deposit
Practical Completion
Fixing
Base



Question 12

6 Points

Put in order the 6 main building stages as per a standard builders contract:

1. Deposit
2. Base
3. Frame
4. Lock-up
5. Fixing
6. Practical Completion



Question 13

1 Point

You have received a copy of a build contract to sign & notice that the builder has nominated \$25 / day for any liquidated damages (late completion). If your peak debt in the project is \$1,000,000 & assuming a 5% interest rate, what would be a reasonable liquidated damages amount to counter with?

- a) \$257 / day $\$1,000,000 @ 5\% = \$1,000,000 \times 0.05 = \$50,000 / \text{year}$
- b) \$53 / day
- c) \$137 / day $\$50,000 / 365 \text{ days} = \$136.98 / \text{day}$
- d) \$312 / day
- e) None of the above - \$25 / day is fair and reasonable

Question 14

7 Points

You are in a meeting with the builder completing the build contract for an investment house build of \$230,000. Complete the progress payment schedule section of the contract.

E.g. $\$230,000 \times 0.05 = \$11,500$

Schedule 2. Progress payments

Part A - Prescribed progress payment schedule

This part applies unless Part B is completed.

Section 66 of the Domestic Building Contracts Act prescribes the following payment schedule:

Stage	Percent	Amount
Deposit	5.00%	\$11,500
Base	10.00%	\$23,000
Frame	15.00%	\$34,500
Enclosed	35.00%	\$80,500
Fxing	20.00%	\$46,000
Practical Completion	15.00%	\$34,500
Total	100.00%	\$230,000

Question 15

In the same meeting with the builder you are reviewing the HIA build contract. What 3 pieces of information are missing from the description of each plan set?

- 1) Author
- 2) Number of Pages
- 3) Date
- 4) Version Number

Special Conditions

3Points

Other documents forming part of the contract:

- Working Drawings – **Samual Designs, Pages 1-7, Version 3, Dated 5/9/16**
- Structural Engineering Plans
- Civil Plans
- Soil / Site Classification Report
- Hydraulic Plans
- Landscape Plan
- Plumbing Approval
- Building Approval – **Coastal Approvals, Pages 1-4, Dated 10/10/16, Version A**

Owner Copy



© Copyright

Page 10 of 36

Initials:



Leader Board

PHASE 3

Execution – Finance, Insurance, Build

Question 16

If you had a signed build contract for \$350,000 and the bank approved an 80% LVR residential construction loan at 5.5% pa interest, what would the loan amount be?



Question 17

Below is the list of insurances that are required for a standard construction project:

- a) Construction / Contract Works Insurance
- b) Home Building & Contents Insurance
- c) Home Warranty Insurance



- 1) What insurance/s must be in place before starting construction?
- 2) What insurance/s must be in place before signing Builders Practical Completion Form?

Question 18

How often should you (or you're your representative) be going to site and meeting with your builder?

- 1) Daily
- 2) Weekly/Fortnightly
- 3) At the end of the project only
- 4) Only when the builder contacts you



Question 19

Under what 2 circumstances would you authorize payment to the builder?

- a) Builders email confirming works completion incl. photos
- b) Bank valuer site inspection
- c) Site inspection by private building inspector / consultant
- d) Building certifier /surveyor inspection
- e) Site inspection by you
- f) Council inspection



Question 20

The plumbing and electrical rough-in is completed during the fix-out stage?

A) TRUE

B) FALSE

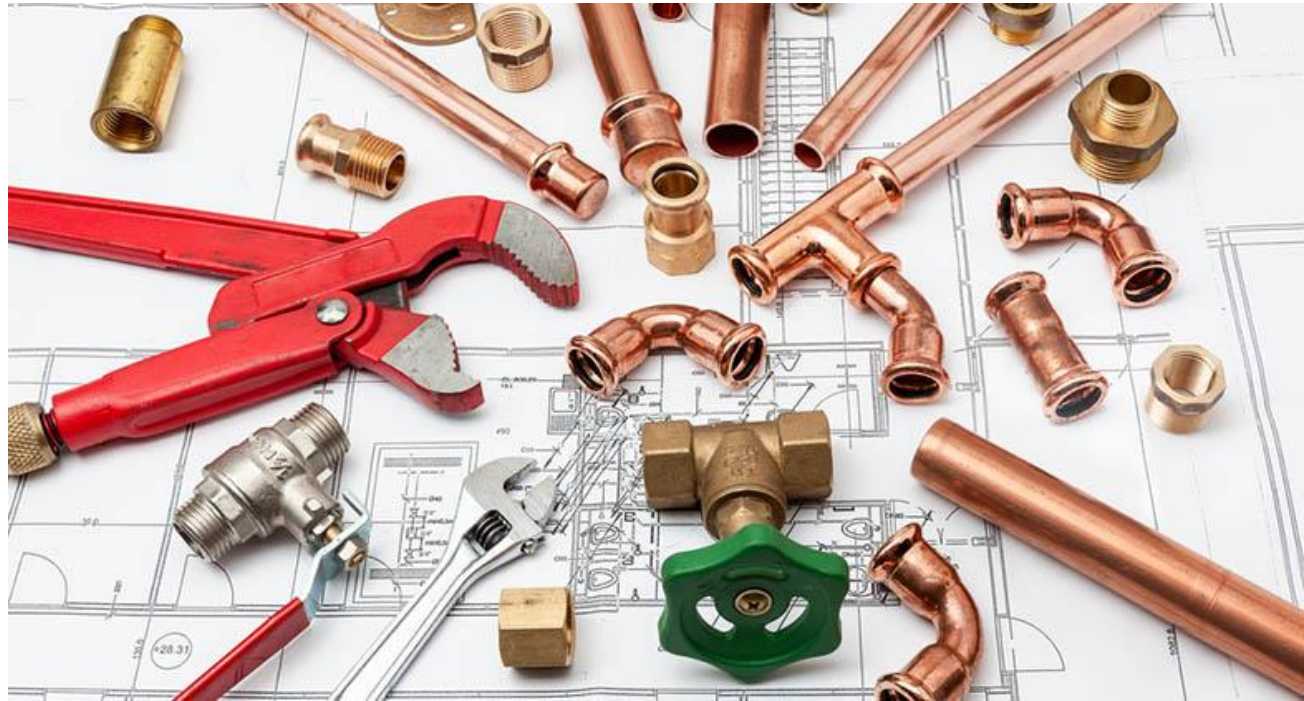

Question 21

If it rains during the build on 20 days and the build contract specified a build period of 126 days including 12 days inclement weather and 41 days weekend and public holidays - how many additional wet weather days can the builder claim and extend the build period by?

- a) 20 days
- b) 32 days
- c) 8 days
- d) 134 days



Question 22

Who issues the occupancy permit at the end of practical completion:

- a) Builder
- b) Quantity Surveyor
- c) Structural Engineer
- d) The Council
- e) Building Surveyor/Certifier

Form 6
OCCUPANCY PERMIT
(Building Act 1993, Building Regulations 2006, Regulation 1005)

Property Details

No: Street/ road: Postcode:
City/ suburb/ town: Postcode:
Lot/s: LP/ PS: Volume: Folio: Crown allot:
Section: Parish:
County: Municipal District:

Building Details*

Part of building: Use: BCA Class:
Allowable floor load: Number of People Deemed
Accommodated:
Part of building: Use: BCA Class:
Allowable floor load: Number of People Deemed
Accommodated:

Places of Public Entertainment**

Place of public entertainment
Prescribed class of temporary structure
Public entertainment to be conducted
Period of operation of this permit

* Complete this portion only if an occupancy permit is required under Division 1 of Part 5 of the Building Act 1993.
** Complete the applicable parts of this portion only if an occupancy permit is required under Division 2 of Part 5 of the Building Act 1993.



Question 23

What are the three main reasons that domestic builders warranty insurance can be claimed on?

- 1)
- 2)
- 3)



ANSWERS

Execution – Finance, Insurance, Build

Question 16

1 Point

If you had a signed build contract for \$350,000 and the bank approved an 80% LVR residential construction loan at 5.5% pa interest, what would the loan amount be?

\$280,000

E.g. \$350,000 @ 80% =
 $\$350,000 \times 0.80 = \$280,000$



Question 17

3 Points

Below is the list of insurances that are required for a standard construction project:

- a) Construction / Contract Works Insurance
- b) Home Building & Contents Insurance
- c) Home Warranty Insurance



- 1) What insurance/s must be in place before starting construction? **a & c**
- 2) What insurance/s must be in place before signing Builders Practical Completion Form? **b**

Question 18

1 Point

How often should you (or you're your representative) be going to site and meeting with your builder?

- 1) Daily
- 2) Weekly/Fortnightly
- 3) At the end of the project only
- 4) Only when the builder contacts you



Question 19

2 Points

Under what 2 circumstances would you authorize payment to the builder?

a) Builders email confirming works completion incl. photos

b) Bank valuer site inspection

c) Site inspection by private building inspector / consultant

d) Building certifier /surveyor inspection

e) Site inspection by you

f) Council inspection

APPROVED

Question 20

1 Point

The plumbing and electrical rough-in is completed during the fix-out stage?

A) TRUE

B) FALSE

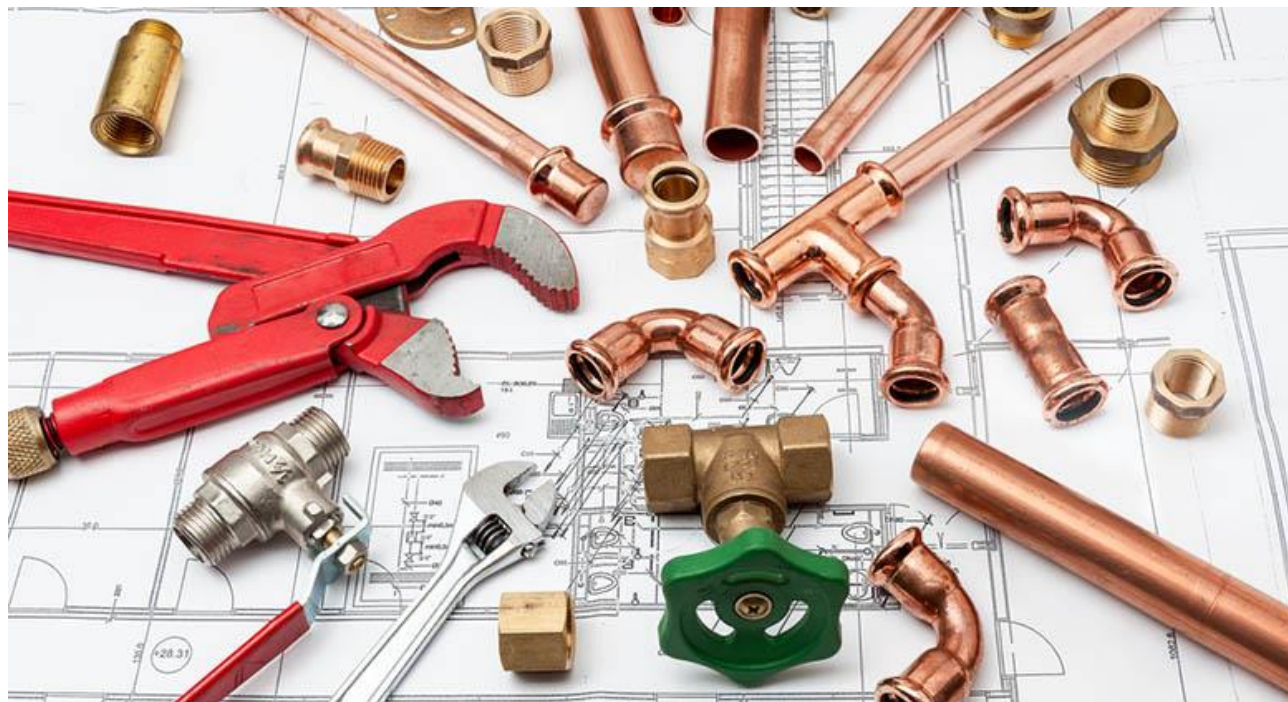

Question 21

1 Point

If it rains during the build on 20 days and the build contract specified a build period of 126 days including 12 days inclement weather and 41 days weekend and public holidays - how many additional wet weather days can the builder claim and extend the build period by?

a) 20 days

b) 32 days

c) 8 days

d) 134 days

E.g. $20 - 12 = 8$



Question 22

1 Point

Who issues the occupancy permit at the end of practical completion:

- a) Builder
- b) Quantity Surveyor
- c) Structural Engineer
- d) The Council
- e) Building Surveyor/Certifier

Form 6
OCCUPANCY PERMIT
(Building Act 1993, Building Regulations 2006, Regulation 1005)

Property Details

No: Street/ road: Postcode:
City/ suburb/ town:
Lot/s: LP/ PS: Volume: Folio: Crown allot:
Section: Parish:
County: Municipal District:

Building Details*

Part of building: Use: BCA Class:
Allowable floor load: Number of People Deemed
Accommodated:
Part of building: Use: BCA Class:
Allowable floor loading: Number of People Deemed
Accommodated:

* Complete this portion only if an occupancy permit is required under Division 1 of Part 5 of the Building Act 1993.

Places of Public Entertainment**

Place of public entertainment
Prescribed class of temporary structure
Public entertainment to be conducted
Period of operation of this permit

** Complete the applicable parts of this portion only if an occupancy permit is required under Division 2 of Part 5 of the Building Act 1993.



Question 23

3 Points

What are the three main reasons that domestic builders warranty insurance can be claimed on?

1) Dyeing

2) Disappearing

3) Insolvency

- Structural defects
- Non-structural defects





Leader Board

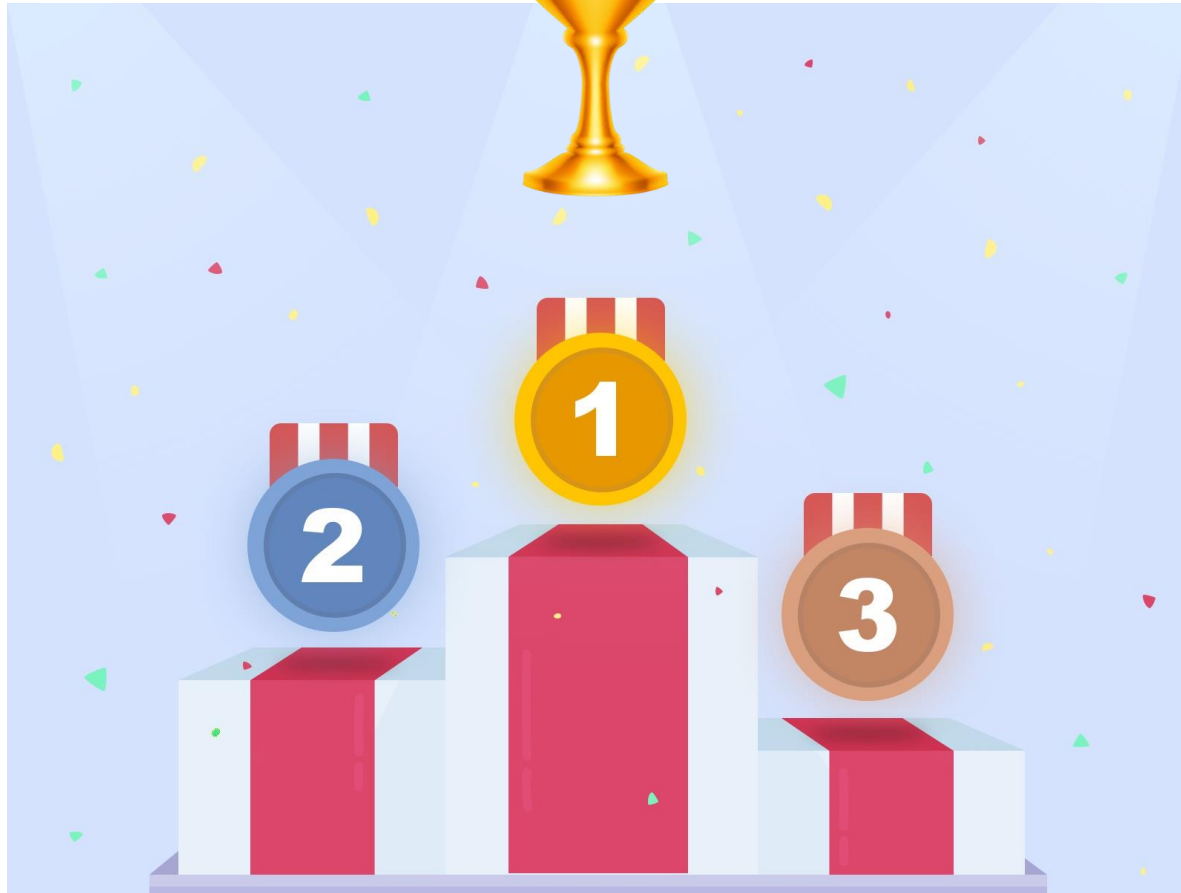

QUESTIONS?