

# PLATINUM

May 2025  
**Construction**

**Mastermind  
Event**

**Brisbane**

---

**Tamara Read  
& Christine Hamilton**  
*QLD State Coach*



**I LOVE**  
REAL ESTATE

# Event Outline -

- 6:00 – 6:30 Networking
- 6:30 - Start
- 6:30 – 6:45 Housekeeping
- 6:45 – 8:00 Personal Development & Accountability
- 8:00 – 8:30 Networking Break
- 8:30 – 10:30 Construction



# Workshop Format

- Use microphone
- Involve everyone in the conversation
- Be supportive
- Feel free to order food and drinks downstairs



# WELCOME NEW PLATINUM'S



- Deb Forbutt\*\*
- Melissa & Nic Rogers\*\*
- Adam Lewis\*\*
- Bernice cooper\*\*
- Amanda Jane Vaughan\*\*
- Jayne Gillespie & Mark\*\*
- Emma Greyson\*\*
- Michelle Jones\*\*
- Rhonda Wisbey

# 2025 DATES

- **1) PA Monthly Dates (Tuesday's)**

**New Venue - Pullman King  
George Square 6pm start**

- ❖ 3<sup>rd</sup> June
- ❖ 1<sup>st</sup> July
- ❖ 12<sup>th</sup> August
- ❖ 2<sup>nd</sup> September
- ❖ 7<sup>th</sup> October
- ❖ 4<sup>th</sup> November
- ❖ 9<sup>th</sup> December

- **2) PA Nationals**

- ❖ 22-25<sup>th</sup> July Boracay
- ❖ 5-7<sup>th</sup> Dec Melbourne

- **3) Ultimate Bootcamps**

- ❖ **2-4<sup>th</sup> May Melbourne**
- ❖ 12-14<sup>th</sup> Sept Brisbane

- **4) Ultimate Other**

- ❖ **21-22<sup>nd</sup> June MW – Zoom\***
- ❖ 14-16<sup>th</sup> Nov Super Conf - Melbourne



PLATINUM  
ACCELERATOR

# INTERNATIONAL CONFERENCE PHILIPPINES

MOVENPICK BORACAY RESORT AND SPA  
TUESDAY 22ND TO FRIDAY 25TH JULY 2025



I LOVE  
REAL ESTATE

Knowledge  
Source



# JULY 2025 International Conf

Date: 22<sup>nd</sup> to 25<sup>th</sup> July 2025

Venue: Movenpick Boracay Resort

Costs: Students to pay own flights, transfers, accommodation, & meals outside of conference meals & Gala dinner

Accom Booking: Venue will offer discounted rate on accom booked via Knowledge Source

Event Booking Open



PLATINUM  
ACCELERATOR

**INTERNATIONAL  
CONFERENCE  
PHILIPPINES**

MOVENPICK BORACAY RESORT AND SPA  
TUESDAY 22ND TO FRIDAY 25TH JULY 2025



I LOVE REAL ESTATE | Knowledge Source



## Raw Impact Charity Partnership

- ❖ Trip Dates - 27<sup>th</sup> July to 2<sup>nd</sup> August
- ❖ Trip Planning Zoom Meeting Date: **28<sup>th</sup>\*\*** **May** 7\*\* pm Sydney Time (\*\* updated)
- ❖ Non-attendees – Can Donate \$ and / or Resources (List to come)



# Money Mind Mastery



Designed to tackle the top 4 Mindset issues that affect ILRE students.

Creating momentum toward success!

All sessions starting 7pm  
Melb/Syd Time

- 26 May
- 4 August
- 25 August
- 29 September
- 27 October
- 24 November

# Platinum Student Meetups

- ❖ PA Website / Platinum Schedule
- ❖ Must have your Facebook account / profile open to access the links

## PLATINUM ACCELERATOR

[Home](#) [Education](#) [Meeting Recordings](#) [Coaches & Contact](#) [Platinum Schedule](#) [Community](#)

### PA Student Meetup Groups

These Student Meetup groups are for ALL Platinum students only, both past and present. They are organised by Platinum students to facilitate networking between Platinums and staying connected with the awesome Platinum family. Typically they occur between the PA Monthly Meetings.

**NOTE: You MUST have your Facebook Account/Profile open to access these links.**

### Brisbane Student Meetup



Student Organizer – Magen Humphreys

Click on the link below to access the Platinum Accelerator Facebook Events for each Brisbane Student Meetup. All of the upcoming dates, location, times and RSVP information is in these events.

[Brisbane Student Meetup](#)

### Sydney Student Meetup



Student Organizer – Dindy Lusk

Click on the link below to access the Platinum Accelerator Facebook Events for each Sydney Student Meetup. All of the upcoming dates, location, times and RSVP information is in these events.

[Sydney Student Meetup](#)

### Melbourne Student Meetup



Student Organizer – Aygun Ozkan

Click on the link below to access the Platinum Accelerator Facebook Events for each Melbourne Student Meetup. All of the upcoming dates, location, times and RSVP information is in these events.

[Melbourne Student Meetup](#)

### Perth Student Meetup



Student Organizer – Basia Garbowska & Heath Worlton

Click on the link below to access the Platinum Accelerator Facebook Events for each Melbourne Student Meetup. All of the upcoming dates, location, times and RSVP information is in these events.

[Perth Student Meetup](#)

# Platinum Student Meetups

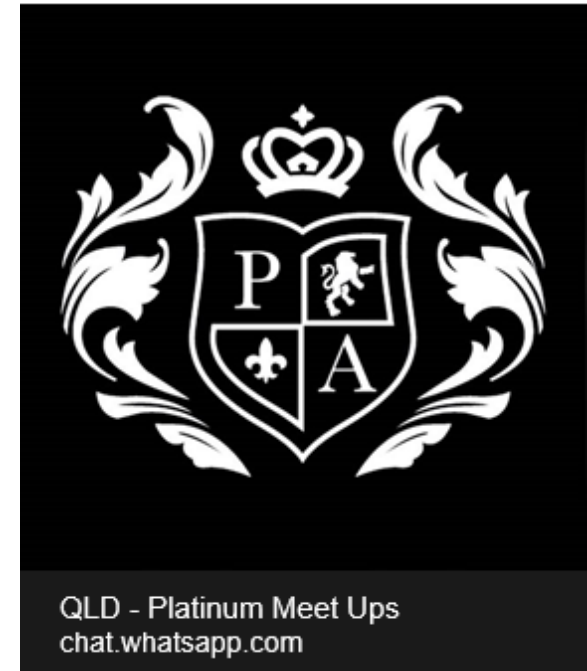
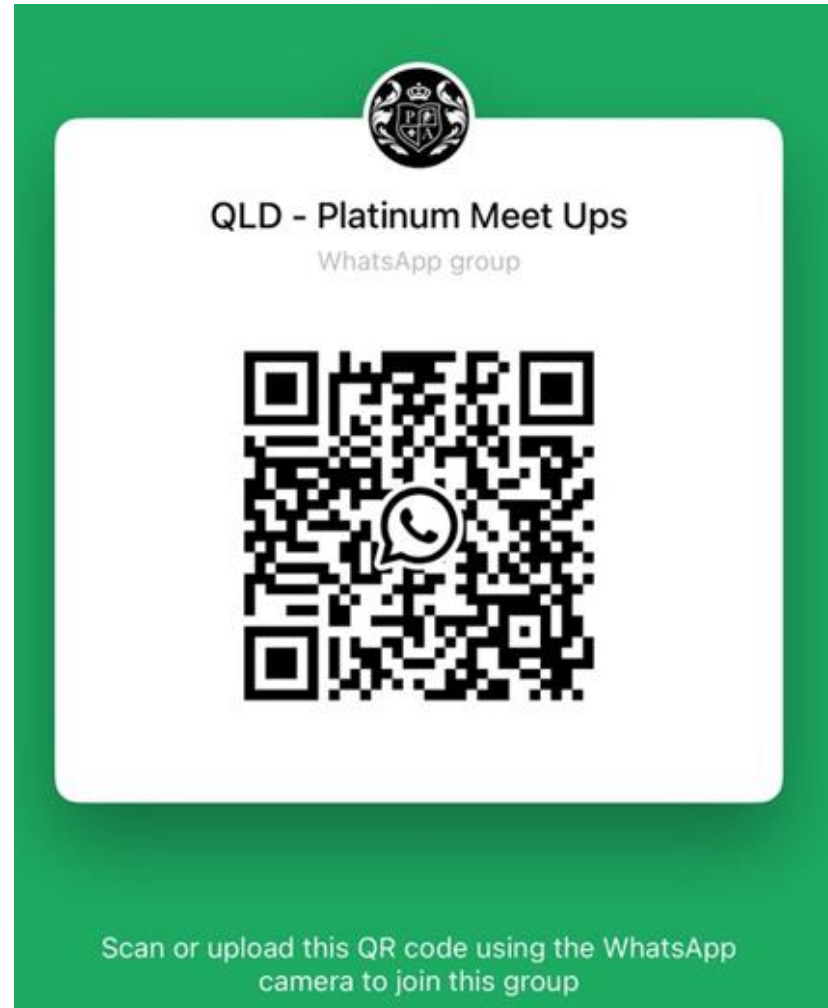

# ILRE Student Meetups

- ❖ Info & RSVP: Ultimate Website / ILRE Community / ILRE Brisbane Meetup / Link to FB Page

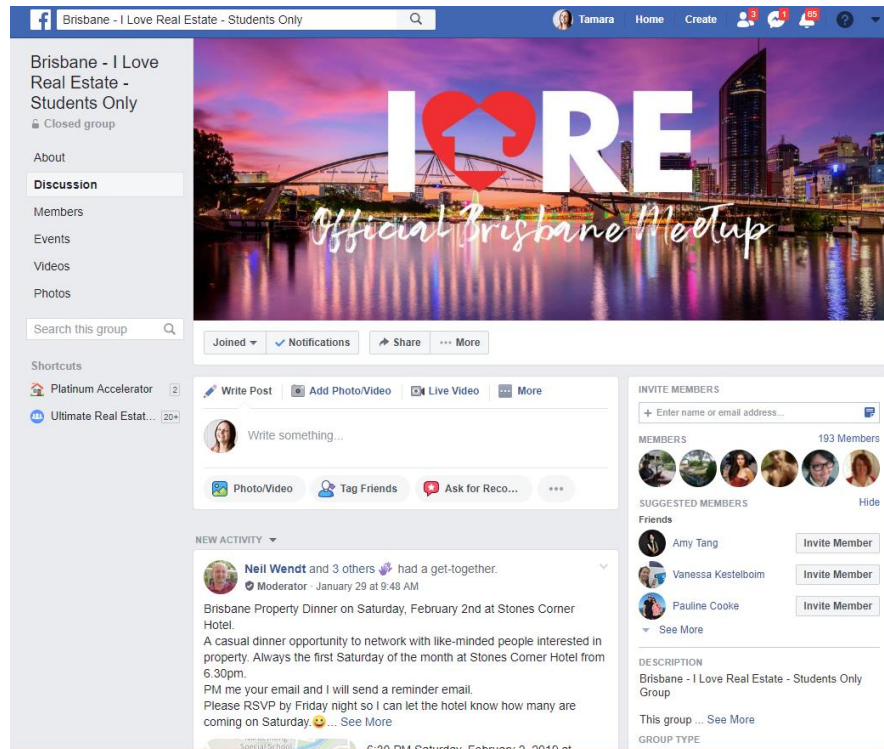

# GRADUATING PLATINUMS



- Shev & Becker
- Bernardine Leth



# STUDENTS OF THE MONTH

# PLATINUM



**I LOVE**  
REAL ESTATE

# Perception

---

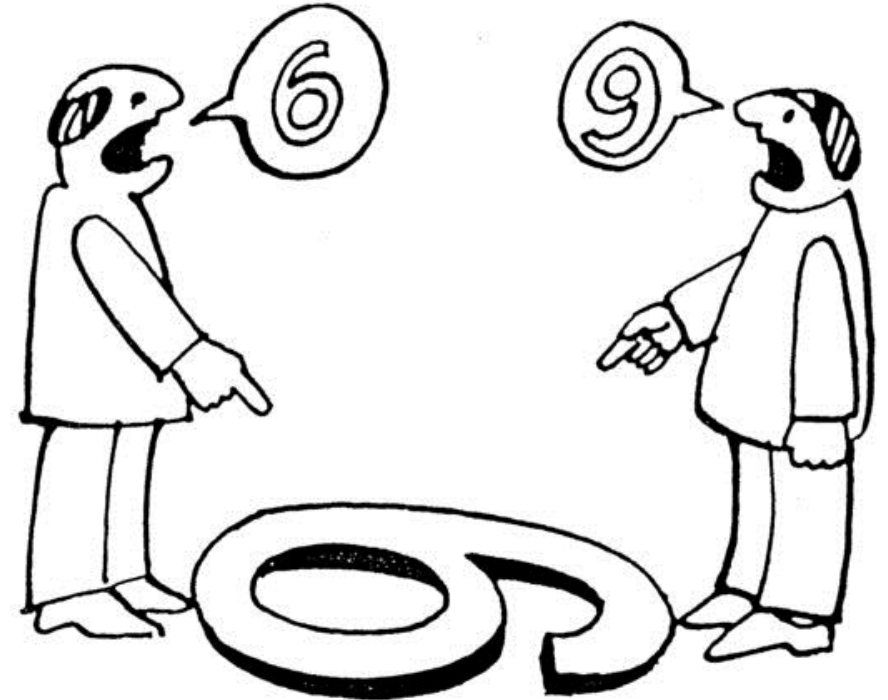



# Perception:

- Can be deceptive
- Determines how we re-act to situations and people
- Determines how people re-act to us
- Can either make relationships or destroy them
- Can either make opportunities or destroy them

Your perception of others and situations determines how you respond to people and situations and therefore what results you get.



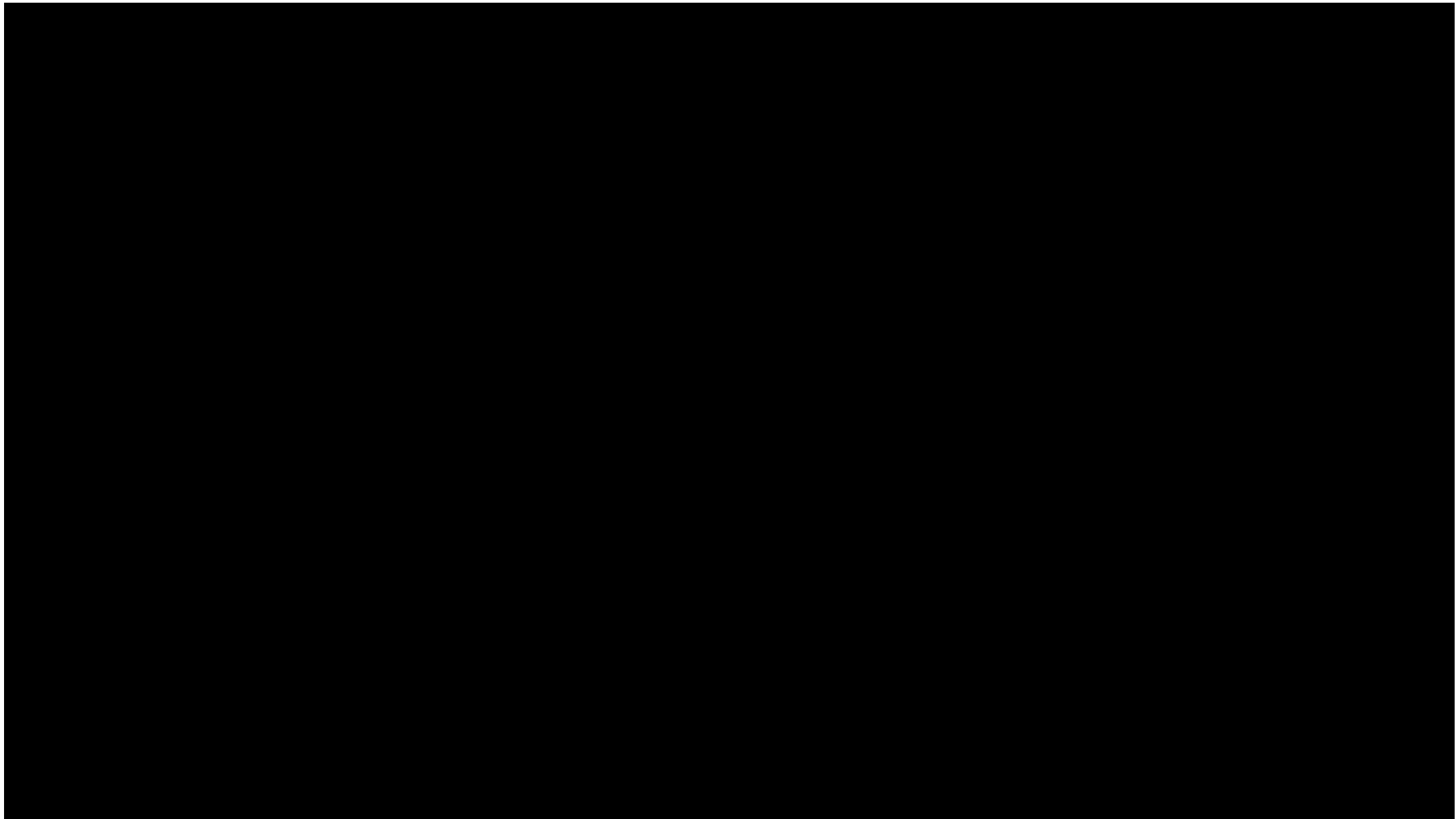

# What do you need to change to get the results you want?

- Is there a situation where you feel you are banging your head against a brick wall?
- What is your attitude around that particular situation?
- What needs to change in you to shift the energy around that situation?
- What steps can you take to get the result you want?
- **REMEMBER – every external experience you are having, you have created in form by your perception and resultant reaction.**

PLATINUM

Accountability  
Monthly Goals



**I LOVE**  
REAL ESTATE

# Buddy Process Follow-Up



- Groups of 3 with others you don't know
- Active Platinum Partners split up (Non-active partners stay together)
- Exchange Mobile No.
- Schedule to "TALK" weekly
- Finishing students partner together

# Last Month In Review

## Share Your Successes and Challenges

SUCCESS

SUCCESS

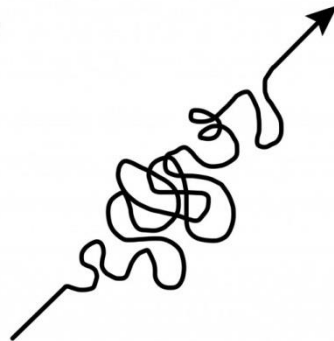
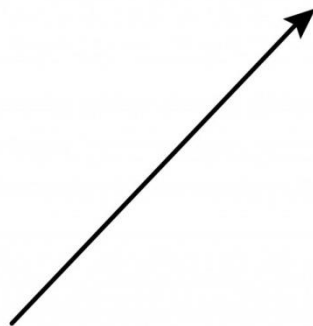

what people think  
it looks like

what it really  
looks like

**This Months Plan**

Share Your  
Key Goals For Month

Monthly  
✓  
goals



# Tea / Coffee Break

# PLATINUM

# CONSTRUCTION

---

# TRIVIA!



**I LOVE**  
REAL ESTATE

# Activity

- Groups of 2-3 people
- Builders & Platinum Elites please answer last in your group – give others a go first 😊
- Record your answers on the recording sheet



TRIVIA – RECORDING SHEET



QU	ANSWER	POINTS
1		
2		
3		
4		
5		
6		
7		
8		
9		
10		
11		
12		
13		
14		
15		
16		
17		
18		
19		
20		
21		
22		
23		

# Construction Process

- Phase 1 – Design, Planning, Team
- Phase 2 – Costings & Contract
- Phase 3 – Execution – Finance, Insurance, Build

**QUESTIONS THEN ANSWERS**

# PHASE 1

Design, Planning, Team

# Question 1

Which professional is the **best** to speak to regarding underground sewer, water and stormwater design and cost estimates:

- a) Town planner
- b) Structural Engineer
- c) Civil Engineer
- b) Land Surveyor



# Question 2 (See Workbook)

## THINGS IN COMMON

	Dual Occupancy (Auxiliary unit)	Dwelling House (Secondary dwelling)	Additional Notes
<b>ONE LOT</b>	✓	✓	Neither a Dual Occupancy (Auxiliary unit) nor a Dwelling House (Secondary dwelling) can be subdivided into two lots.
<b>COMPARATIVE SIZE</b>	✓	✓	Unlike a traditional Dual Occupancy (duplex) one dwelling must be 'big' (the primary dwelling) and one must be 'small' (the Auxiliary unit / Secondary dwelling).
<b>GROSS FLOOR AREA (GFA)</b>	✓	✓	The maximum size of the Auxiliary unit / Secondary dwelling is restricted to: <ul style="list-style-type: none"> <li>• 70m<sup>2</sup> if in the residential zone category and on a lot less than 1000m<sup>2</sup> in size or</li> <li>• 100m<sup>2</sup> if in the residential zone category and on lots over 1000m<sup>2</sup> in size</li> </ul> GFA excludes garages, carports, decks and patios.
<b>LOCATION</b>	✓	✓	In addition to the standard building setbacks of the planning scheme, both forms of development can be located beside, incorporated within (above or under) or behind but not in front of the primary dwelling.
<b>SELF CONTAINED</b>	✓	✓	Both can be self-contained and have separate entrances.
<b>RUBBISH BIN</b>	✓	✓	Additional bins are permitted subject to charge.
<b>ATTACHED</b>	✓	✓	Both dwelling can be attached or separated by no more than 20m.



# Question 2

Based on the information provided, assuming that you have found a property that's 600m<sup>2</sup> in total land size, in the residential zone, that has enough room to the side of the existing dwelling to construct this design, with adequate parking and only one crossover (entry). Would this floor plan fit the planning / design criteria to be approved as an auxiliary dwelling (granny flat)?

- a) True
- b) False

# Question 3

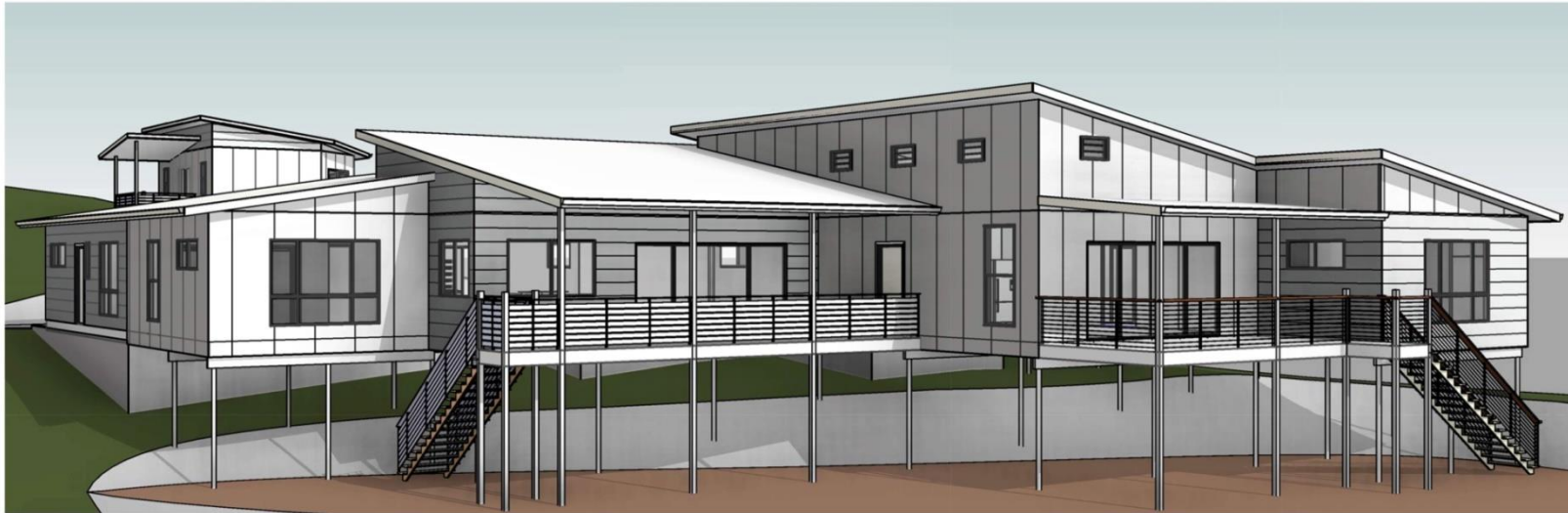

List at least 4 cost saving ideas:

1) \_\_\_\_\_

2) \_\_\_\_\_

3) \_\_\_\_\_

4) \_\_\_\_\_

# Question 4

On the 1012m<sup>2</sup> property below (highlighted yellow boundaries), calculate the maximum area for a building to cover, inclusive of garages and patios.



## Planning Information:

- Height allowance 9mtrs
- 1 dwelling / 250m<sup>2</sup>
- 5 metre front setback
- 6 metre rear setback
- 2 metre side setback
- Site coverage 60%

# Question 5

When sourcing multiple build quotes – list 3 ways to reduce the variability between quotes.

1) \_\_\_\_\_

2) \_\_\_\_\_

3) \_\_\_\_\_



# Question 6

List 5 ways to source a builder in your area?

1) \_\_\_\_\_

2) \_\_\_\_\_

3) \_\_\_\_\_

4) \_\_\_\_\_

5) \_\_\_\_\_



# Question 7

List 5 examples of how you can complete a due diligence check on a builder?

1) \_\_\_\_\_

2) \_\_\_\_\_

3) \_\_\_\_\_

4) \_\_\_\_\_

5) \_\_\_\_\_



# ANSWERS

Design, Planning, Team

# Question 1

1 Point

Which professional is the **best** to speak to regarding underground sewer, water and stormwater design and cost estimates:

- a) Town planner
- b) Structural Engineer
- c) Civil Engineer
- b) Land Surveyor



# Question 2 (References)

## THINGS IN COMMON

	Dual Occupancy (Auxiliary unit)	Dwelling House (Secondary dwelling)	Additional Notes
<b>ONE LOT</b>	✓	✓	Neither a Dual Occupancy (Auxiliary unit) nor a Dwelling House (Secondary dwelling) can be subdivided into two lots.
<b>COMPARATIVE SIZE</b>	✓	✓	Unlike a traditional Dual Occupancy (duplex) one dwelling must be 'big' (the primary dwelling) and one must be 'small' (the Auxiliary unit / Secondary dwelling).
<b>GROSS FLOOR AREA (GFA)</b>	✓	✓	The maximum size of the Auxiliary unit / Secondary dwelling is restricted to: <ul style="list-style-type: none"> <li>• 70m<sup>2</sup> if in the residential zone category and on a lot less than 1000m<sup>2</sup> in size or</li> <li>• 100m<sup>2</sup> if in the residential zone category and on lots over 1000m<sup>2</sup> in size</li> </ul> GFA excludes garages, carports, decks and patios.
<b>LOCATION</b>	✓	✓	In addition to the standard building setbacks of the planning scheme, both forms of development can be located beside, incorporated within (above or under) or behind but not in front of the primary dwelling.
<b>SELF CONTAINED</b>	✓	✓	Both can be self-contained and have separate entrances.
<b>RUBBISH BIN</b>	✓	✓	Additional bins are permitted subject to charge.
<b>ATTACHED</b>	✓	✓	Both dwelling can be attached or separated by no more than 20m.



## Question 2

1 Point

Based on the information provided, assuming that you have found a property that's 600m<sup>2</sup> in total land size, in the residential zone, that has enough room to the side of the existing dwelling to construct this design, with adequate parking and only one crossover (entry). Would this floor plan fit the planning / design criteria to be approved as an auxiliary dwelling (granny flat)?

a) True

b) False

# Question 3

**4 Points**

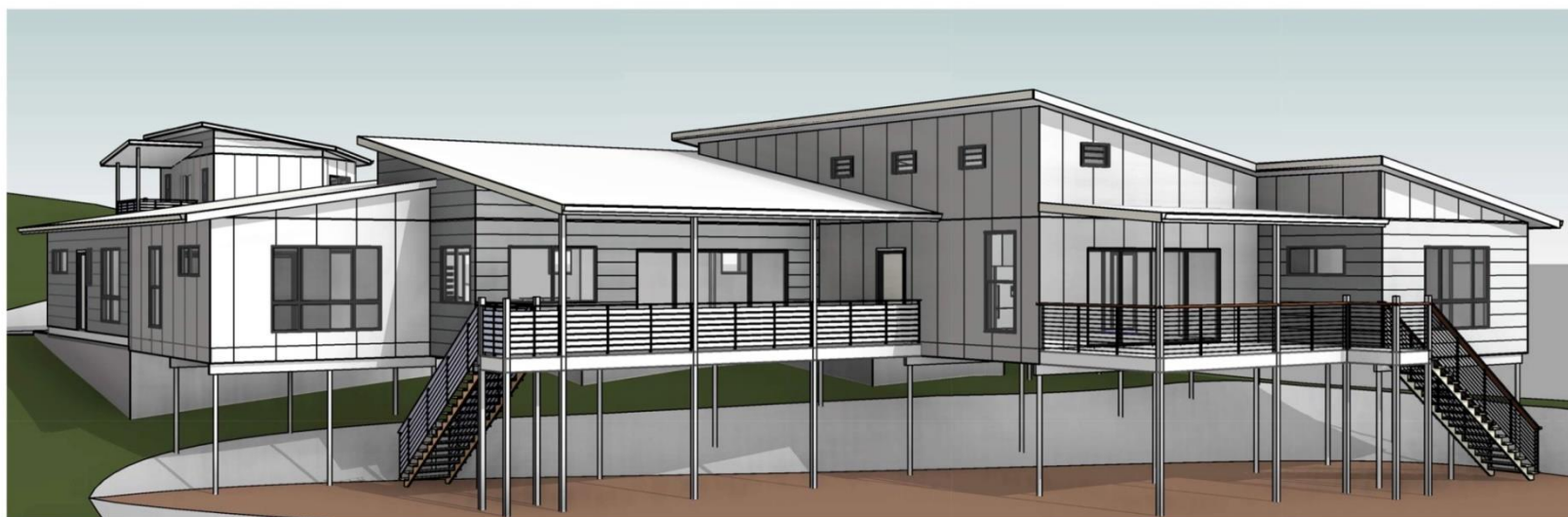

List at least 4 cost saving ideas:

**Reduce:**

1) Floor area

2) Wall articulation

3) Roof complexity

4) Ceiling height

- High windows

- Driveway concrete

# Question 4

1 Point

On the 1012m<sup>2</sup> property below (highlighted yellow boundaries), calculate the maximum area for a building to cover, inclusive of garages and patios.



## Planning Information:

- Height allowance 9mtrs
- 1 dwelling / 250m<sup>2</sup>
- 5 metre front setback
- 6 metre rear setback
- 2 metre side setback
- Site coverage 60%

$$1012\text{m}^2 \times 0.6 = 607\text{m}^2$$

# Question 5

**3 Points**

When sourcing multiple build quotes – list 3 ways to reduce the variability between quotes.

- 1) Provide specifications document
- 2) Make selection of finishes up front – make/model/photos  
Provide prime cost allowances
- 3) for items not yet selected e.g. tiles
  - Provide electrical plans, tiling plan etc.
  - Do detailed soil testing where rock may exist – assist groundworks



# Question 6

**5 Points**

List 5 ways to source a builder in your area?

- 1) Referrals
- 2) Builders signs around neighborhood
- 3) Building broker
- 4) Building association
- 5) Visit display village

- Internet search (i.e. Google); Realestate agent selling new product



# Question 7

**5 Points**

List 5 examples of how you can complete a due diligence check on a builder?

1) View finished projects – recent & older

2) Call insurers

3) Speak to real estate agents that sold previous

4) Make contact with existing clients

5) Visit tradies & ask questions



- Contact suppliers
- Call Building License Authority – do building license search
- Do ASIC Company search



## Leader Board

# PHASE 2

## Costings & Contract

# Question 8

When it comes to calculating build costs, which group below is the most appropriate:

- a) Town planner, land surveyor, council, designer / architect
- b) Designer / architect, land surveyor, builder
- c) Town planner, structural engineer, civil engineer, traffic engineer
- d) Builders, designer / architect, quantity surveyors
- e) Dymphna and your coach

# Question 9

When you ask a builder for a \$ / sq mtr rate, this normally means that it's a full turn key, medium level spec, fully approved (incl. approvals, certification etc.), inclusive of all garages, patio and inclusive of GST?

a) True

b) False

# Question 10

All 3 designs are 250m<sup>2</sup> in area. List 3 reasons why it is inaccurate to refer to square meterage rates from a builder?

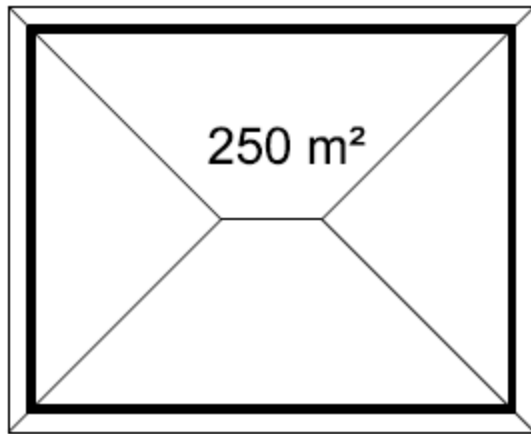

DESIGN A

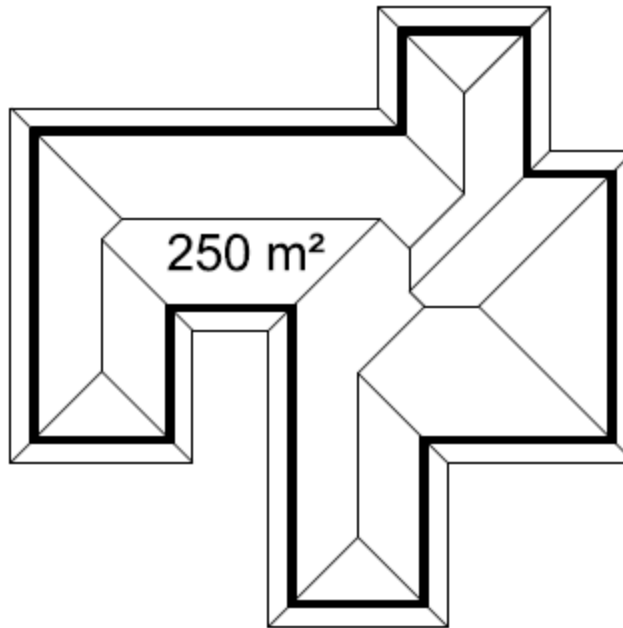

DESIGN B

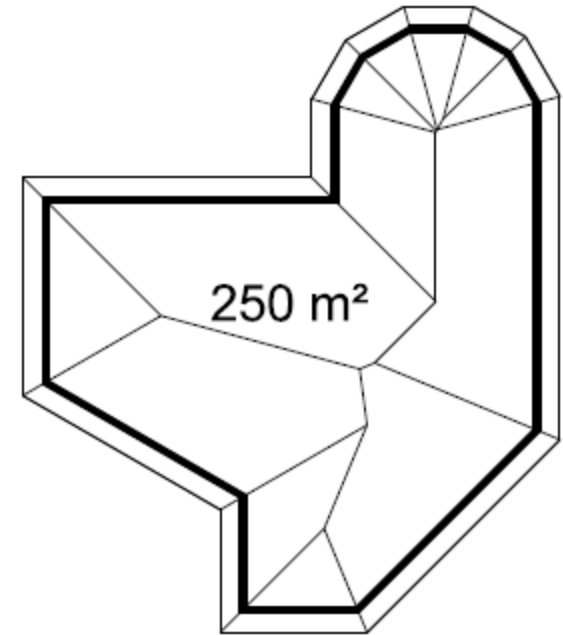

DESIGN C

# Question 11

Which 3 items might be listed as prime cost items in a builder's quote?

- a) Rock Excavation
- b) Oven
- c) Tiles
- d) Landscaping
- e) Front door
- f) Fencing



# Question 12

Put in order the 6 main building stages as per a standard builder's contract:

Lock-up  
Deposit  
Fixing  
Frame  
Practical Completion  
Base



# Question 13

You have received a copy of a build contract to sign & notice that the builder has nominated \$25 / day for any liquidated damages (late completion). If your peak debt in the project is \$1,000,000 & assuming a 5% interest rate, what would be a reasonable liquidated damages amount to counter with?

- a) \$257 / day
- b) \$53 / day
- c) \$137 / day
- d) \$312 / day
- e) None of the above - \$25 / day is fair and reasonable



# Question 14 (See Workbook)

You are in a meeting with the builder completing the build contract for a house build of \$230,000. Complete the progress payment schedule section of the contract.

## Schedule 2. Progress payments

### Part A - Prescribed progress payment schedule

This part applies unless Part B is completed.

Section 66 of the Domestic Building Contracts Act prescribes the following payment schedule:

Stage	Percent	Amount
Deposit	5.00%	
Base	10.00%	
Frame	15.00%	
Enclosed	35.00%	
Fxing	20.00%	
Practical Completion	15.00%	
Total	100.00%	

# Question 15

In the same meeting with the builder, you are reviewing the HIA build contract. What 3 pieces of information are missing from the description of each plan set?

## Special Conditions

Other documents forming part of the contract:

- Working Drawings
- Structural Engineering Plans
- Civil Plans
- Soil / Site Classification Report
- Hydraulic Plans
- Landscape Plan
- Plumbing Approval
- Building Approval

Owner Copy



# ANSWERS

## Costings & Contract

# Question 8

1 Point

When it comes to calculating build costs, which group below is the most appropriate:

- a) Town planner, land surveyor, council, designer / architect
- b) Designer / architect, land surveyor, builder
- c) Town planner, structural engineer, civil engineer, traffic engineer
- d) Builders, designer / architect, quantity surveyors
- e) Dymphna and your coach

# Question 9

1 Point

When you ask a builder for a \$ / sq mtr rate, this normally means that it's a full turn key, medium level spec, fully approved (incl. approvals, certification etc.), inclusive of all garages, patio and inclusive of GST?

a) True

b) False



# Question 10

**3 Points**

All 3 designs are 250m<sup>2</sup> in area. List 3 reasons why it is inaccurate to refer to square meterage rates from a builder?

- External wall length differs
- Roof complexity differs
- Custom design effects price – complex angles, custom windows / joinery

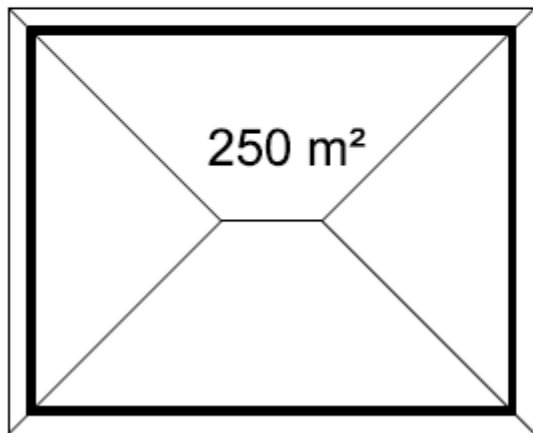

DESIGN A

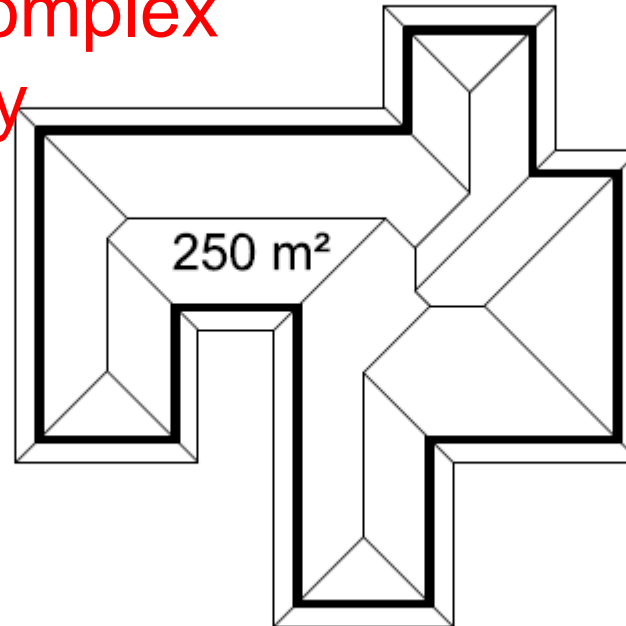

DESIGN B

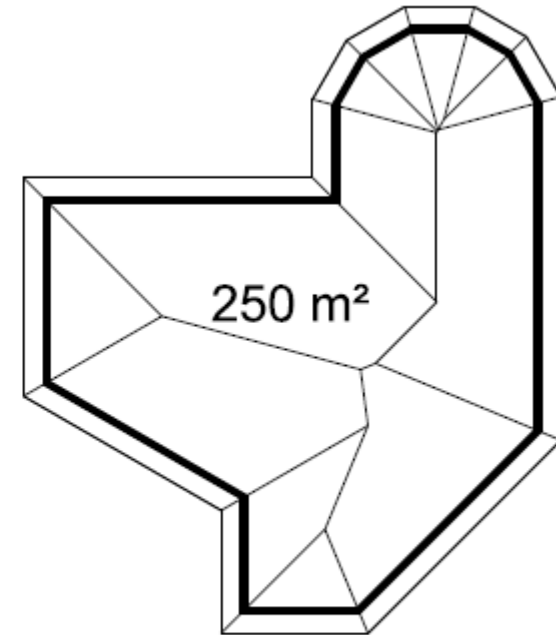

DESIGN C

# Question 11

**3 Points**

Which 3 items might be listed as prime cost items in a builder's quote?

- a) Rock Excavation
- b) Oven
- c) Tiles
- d) Landscaping
- e) Front door
- f) Fencing



# Question 12

Put in order the 6 main building stages as per a standard builder's contract:

Lock-up  
Deposit  
Fixing  
Frame  
Practical Completion  
Base



# Question 12

**6 Points**

Put in order the 6 main building stages as per a standard builders contract:

1. Deposit
2. Base
3. Frame
4. Lock-up
5. Fixing
6. Practical Completion



# Question 13

**1 Point**

You have received a copy of a build contract to sign & notice that the builder has nominated \$25 / day for any liquidated damages (late completion). If your peak debt in the project is \$1,000,000 & assuming a 5% interest rate, what would be a reasonable liquidated damages amount to counter with?

- a) \$257 / day       $\$1,000,000 @ 5\% = \$1,000,000 \times 0.05 = \$50,000 / \text{year}$
- b) \$53 / day
- c) \$137 / day       $\$50,000 / 365 \text{ days} = \$136.98 / \text{day}$
- d) \$312 / day
- e) None of the above - \$25 / day is fair and reasonable

# Question 14

7 Points

You are in a meeting with the builder completing the build contract for an investment house build of \$230,000. Complete the progress payment schedule section of the contract.

E.g.  $\$230,000 \times 0.05 = \$11,500$

## Schedule 2. Progress payments

### Part A - Prescribed progress payment schedule

This part applies unless Part B is completed.

Section 66 of the Domestic Building Contracts Act prescribes the following payment schedule:

Stage	Percent	Amount
Deposit	5.00%	\$11,500
Base	10.00%	\$23,000
Frame	15.00%	\$34,500
Enclosed	35.00%	\$80,500
Fxing	20.00%	\$46,000
Practical Completion	15.00%	\$34,500
Total	100.00%	\$230,000

# Question 15

In the same meeting with the builder you are reviewing the HIA build contract. What 3 pieces of information are missing from the description of each plan set?

- 1) Author
- 2) Number of Pages
- 3) Date
- 4) Version Number

## Special Conditions

**3Points**

Other documents forming part of the contract:

- Working Drawings – **Samual Designs, Pages 1-7, Version 3, Dated 5/9/16**
- Structural Engineering Plans
- Civil Plans
- Soil / Site Classification Report
- Hydraulic Plans
- Landscape Plan
- Plumbing Approval
- Building Approval – **Coastal Approvals, Pages 1-4, Dated 10/10/16, Version A**

Owner Copy



© Copyright

Page 10 of 36

Initials:



## Leader Board

# PHASE 3

Execution – Finance, Insurance, Build

# Question 16

If you had a signed build contract for \$350,000 and the bank approved an 80% LVR residential construction loan at 5.5% pa interest, what would the loan amount be?



# Question 17

Below is the list of insurances that are required for a standard construction project:

- a) Construction / Contract Works Insurance
- b) Home Building & Contents Insurance
- c) Home Warranty Insurance



- 1) What insurance/s must be in place before starting construction?
- 2) What insurance/s must be in place before signing Builder's Practical Completion Form?

# Question 18

How often should you (or you're your representative) be going to site and meeting with your builder?

- 1) Daily
- 2) Weekly/Fortnightly
- 3) At the end of the project only
- 4) Only when the builder contacts you



# Question 19

Under what 2 circumstances would you authorize payment to the builder?

- a) Builder's email confirming works completion incl. photos
- b) Bank valuer site inspection
- c) Site inspection by private building inspector / consultant
- d) Building certifier /surveyor inspection
- e) Site inspection by you
- f) Council inspection



# Question 20

The plumbing and electrical rough-in is completed during the fix-out stage?

A) TRUE

B) FALSE

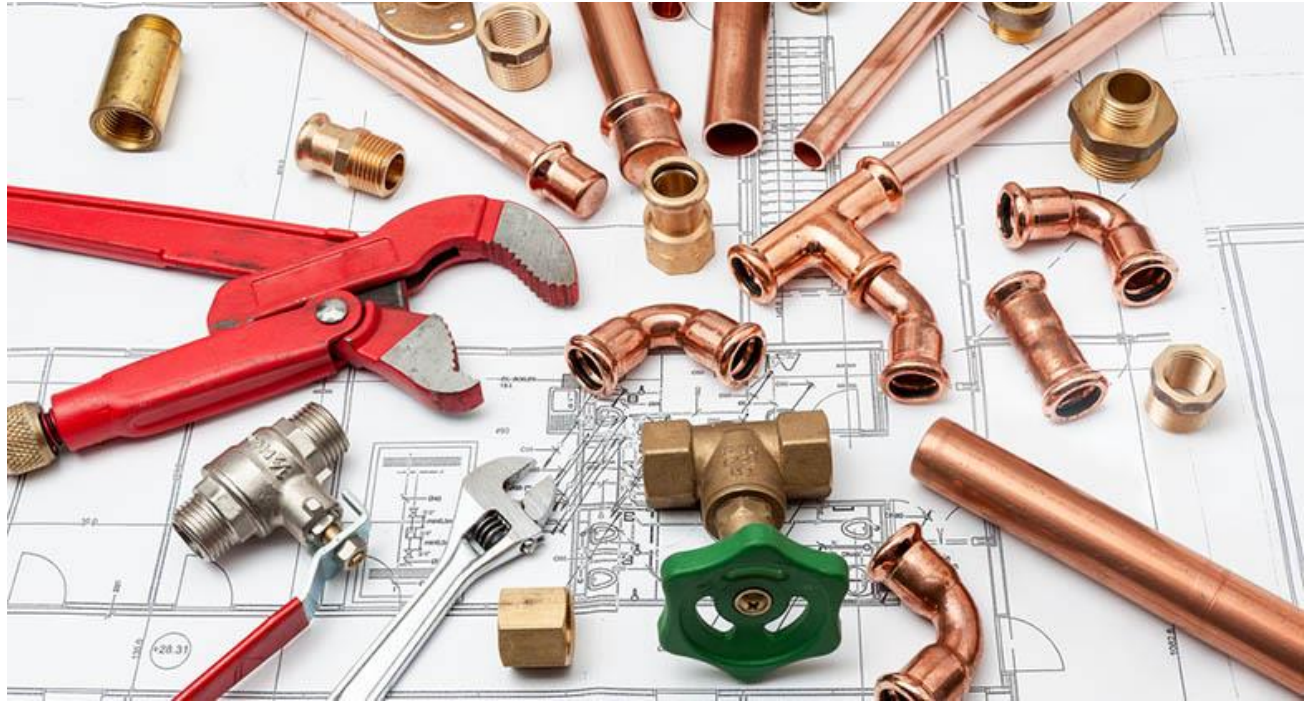

# Question 21

If it rains during the build for 20 days and the build contract specified a build period of 126 days including 12 days inclement weather and 41 days weekend and public holidays - how many additional wet weather days can the builder claim and extend the build period by?

- a) 20 days
- b) 32 days
- c) 8 days
- d) 134 days





# Question 23

What are the three main reasons that domestic builders warranty insurance can be claimed on?

- 1) .....
- 2) .....
- 3) .....



# ANSWERS

Execution – Finance, Insurance, Build

# Question 16

1 Point

If you had a signed build contract for \$350,000 and the bank approved an 80% LVR residential construction loan at 5.5% pa interest, what would the loan amount be?

\$280,000

E.g. \$350,000 @ 80% =  
 $\$350,000 \times 0.80 = \$280,000$



# Question 17

**3 Points**

Below is the list of insurances that are required for a standard construction project:

- a) Construction / Contract Works Insurance
- b) Home Building & Contents Insurance
- c) Home Warranty Insurance



- 1) What insurance/s must be in place before starting construction? **a & c**
- 2) What insurance/s must be in place before signing Builder's Practical Completion Form? **b**

# Question 18

**1 Point**

How often should you (or you're your representative) be going to site and meeting with your builder?

- 1) Daily
- 2) Weekly/Fortnightly
- 3) At the end of the project only
- 4) Only when the builder contacts you



# Question 19

**2 Points**

Under what 2 circumstances would you authorize payment to the builder?

- a) Builder's email confirming works completion incl. photos
- b) Bank valuer site inspection
- c) Site inspection by private building inspector / consultant
- d) Building certifier /surveyor inspection
- e) Site inspection by you
- f) Council inspection



# Question 20

1 Point

The plumbing and electrical rough-in is completed during the fix-out stage?

A) TRUE

B) FALSE

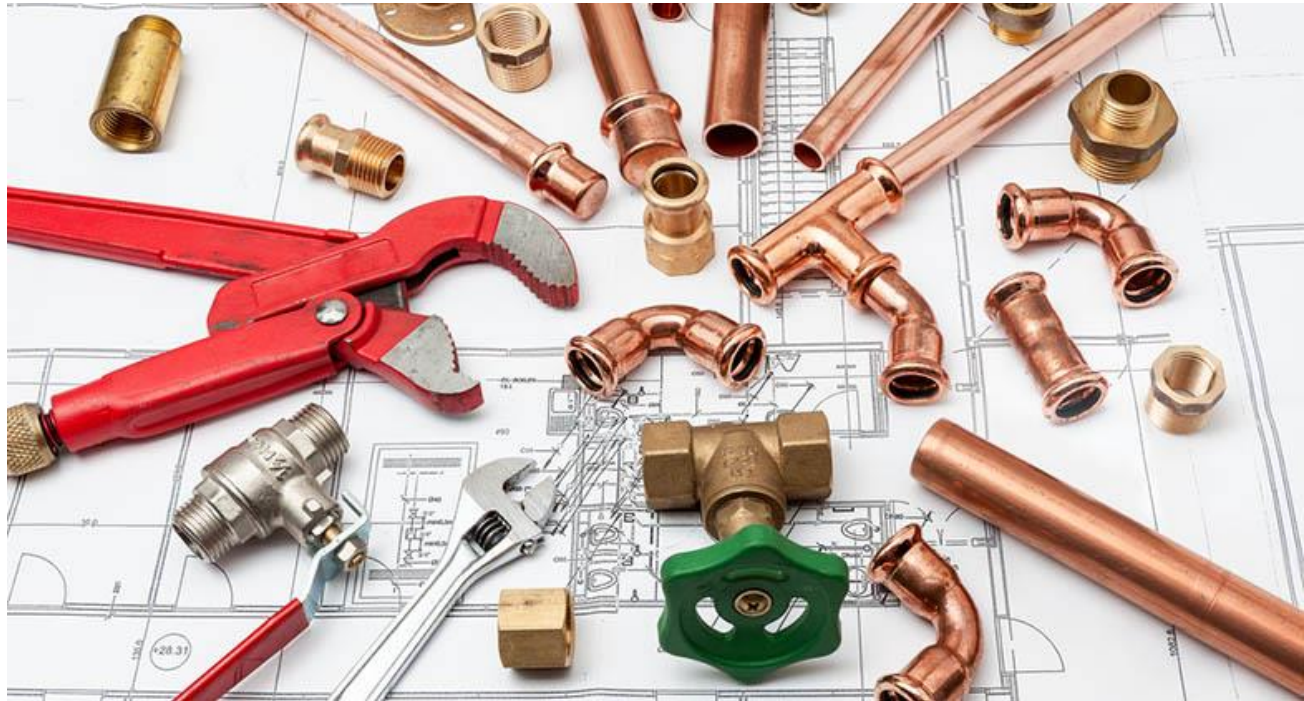

# Question 21

1 Point

If it rains during the build for 20 days and the build contract specified a build period of 126 days including 12 days inclement weather and 41 days weekend and public holidays - how many additional wet weather days can the builder claim and extend the build period by?

a) 20 days

b) 32 days

c) 8 days

d) 134 days

E.g.  $20 - 12 = 8$



# Question 22

1 Point

Who issues the occupancy permit at the end of practical completion:

- a) Builder
- b) Quantity Surveyor
- c) Structural Engineer
- d) The Council
- e) Building Surveyor/Certifier

Form 6  
OCCUPANCY PERMIT  
(Building Act 1993, Building Regulations 2006, Regulation 1005)

#### Property Details

No: Street/ road: Postcode:  
City/ suburb/ town:  
Lot/s: LP/ PS: Volume: Folio: Crown allot:  
Section: Parish:  
County: Municipal District:

#### Building Details\*

Part of building: Use: BCA Class:  
Allowable floor load: Number of People Deemed  
Accommodated:  
Part of building: Use: BCA Class:  
Allowable floor load: Number of People Deemed  
Accommodated:

\* Complete this portion only if an occupancy permit is required under Division 1 of Part 5 of the Building Act 1993.

#### Places of Public Entertainment\*\*

Place of public entertainment  
Prescribed class of temporary structure  
Public entertainment to be conducted  
Period of operation of this permit

\*\* Complete the applicable parts of this portion only if an occupancy permit is required under Division 2 of Part 5 of the Building Act 1993.



# Question 23

**3 Points**

What are the three main reasons that domestic builders warranty insurance can be claimed on?

1) Dying

2) Disappearing

3) Insolvency

- Structural defects
- Non-structural defects





# Leader Board

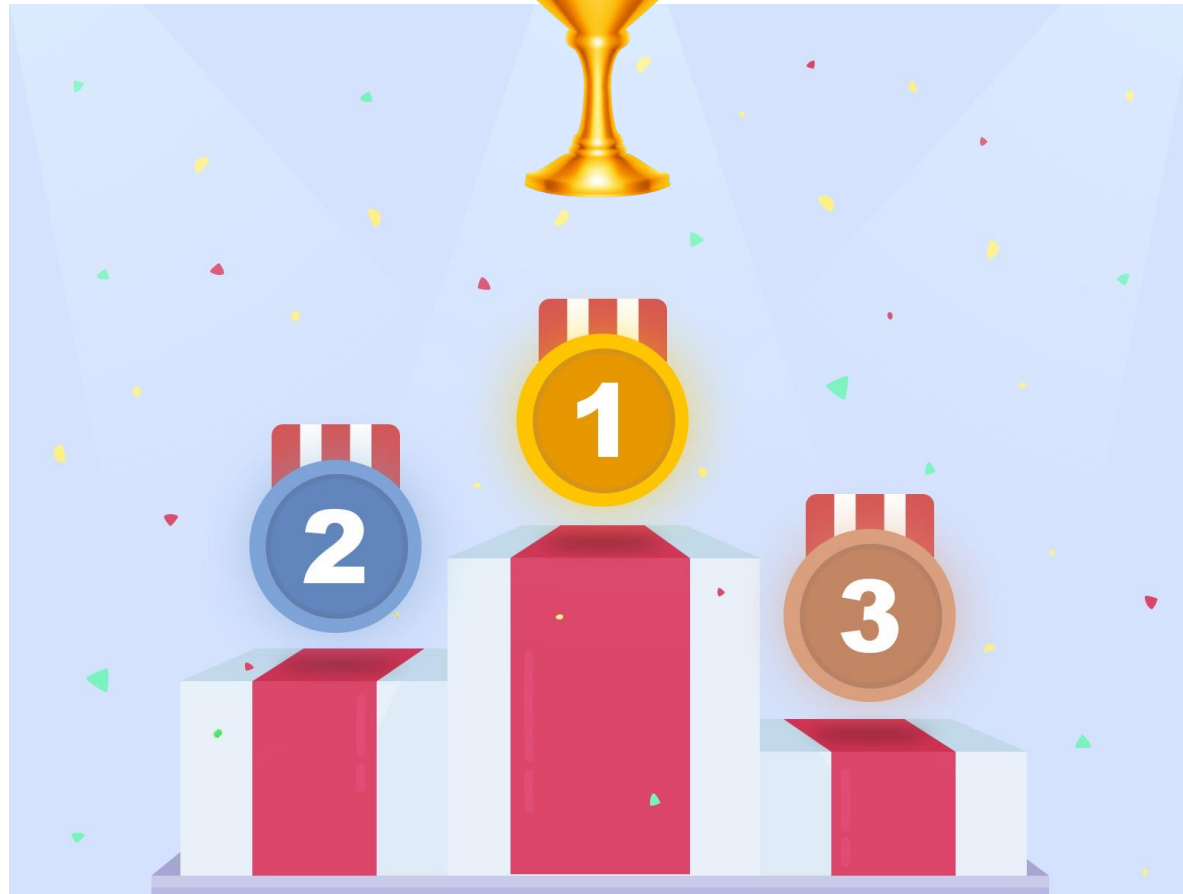

QUESTIONS?